



video game data library

vol. III

tokenonly.com 2010

special thanks to p1001

TABLE OF CONTENTS

1. GENERAL INFORMATION	1	5.2 OOB		12. MINE CIRCUITRY	16
1.1 General Introduction		5.3 Tank Resets		12.1 Functions	
1.2 Logic Symboly & Notation		5.4 HMCE		12.2 Mine Matrix	
1.3 Two Printed Circuit Boards		5.5 BLO-UP 1 & BLO-UP 2		12.3 Minefield	
1.4 Glossary of Signal Names		5.6 FLASH & TM1		12.4 Mine Control	
1.5 Test Equipment		6. TANK CONTROL	8	13. VERTICAL & HORIZONTAL LOAD	20
1.6 Video Probe Connection		6.1 Functions		13.1 Functions	
1.7 The Game Sequence		6.2 Tank Rotation & Speed		13.2 Horizontal Load	
1.8 TV & PCB Adjustments		6.3 Acceleration		13.3 Vertical Load	
1.9 General Architecture		6.4 Braking		14. TANK MOTION	21
2. THE POWER SUPPLIES	3	6.5 Clockwise Rotation		14.1 Motion Latches	
2.1 Functions		6.6 Counter-Clockwise Rotation		14.2 Horizontal Motion Latches	
2.2 The +5 Volt Supplies		7. SHELL CONTROL & BOUNCE	11	14.3 Vertical Motion Latches	
2.3 The +12 & -12 Volt Supplies		7.1 Functions		14.4 Motion	
3. THE CREDIT CIRCUITRY	4	7.2 Shell Control		14.5 Tank Motion Circuits	
3.1 Functions		7.3 White Shell Adjustment		14.6 Horizontal Tank Motion	
3.2 The Coin Counter		7.4 Bounce		14.7 Vertical Tank Motion	
3.3 The Coin Circuit		8. SCORE	13	14.8 WINDOW 1	
3.4 25¢/50¢ Switch		8.1 Score Generation		14.9 Tank Display	
3.5 ATTRACT		8.2 Score Increment & Storage		15. SHELL MOTION	23
3.6 The Anti-Static Circuit		8.3 Score Events		15.1 Construction	
3.7 Game Timer		8.4 Operations		15.2 Horizontal Shell Latches	
3.8 Game Near End		9. THE MEMORY	14	15.3 Horizontal Shell Motion	
4. MAIN TIMING	5	9.1 Functions		15.4 Vertical Shell Latches	
4.1 Interlaced Raster Scan		9.2 Preliminary Multiplexing		15.5 Vertical Shell Motion	
4.2 The Oscillator		9.3 Address Multiplexing		15.6 SRS 1	
4.3 Synchronization		9.4 Score Data		15.7 SHELL 1 Video	
4.4 Horizontal Main Timing		9.5 Position Data		15.8 BLAST 1 Video	
4.5 Horizontal Reset		9.6 Playfield Data		16. SOUND CIRCUITRY	25
4.6 Horizontal Blanking		9.7 Tank Aspect Data		16.1 Functions	
4.7 Horizontal Sync		10. PLAYFIELD & SCORE LOAD	15	16.2 SHOT & BOOM COM	
4.8 H INFO		10.1 Functions		16.3 SHOT COM	
4.9 Vertical Timing		10.2 Score Load		16.4 BOOM COM	
4.10 Vertical Reset		10.3 Playfield Load		16.5 NOISE	
4.11 Vertical Sync		10.4 PFLD		16.6 Shot Sound	
4.12 V INFO		11. VIDEO SUMMATION	16	16.7 Boom Sound	
4.13 COMP SYNC		11.1 Functions		16.8 Motor Sounds	
5. MISCELLANEOUS CONTROL SIGNALS	8	11.2 Operation		16.9 The Audio Amplifiers	
5.1 RESET 2					

SECTION 1

GENERAL INFORMATION

1.1 General Introduction: **Tank** is a very playable and realistic simulation of genuine tank combat where the goal is to fire upon and hit the "enemy" tank. The realism and effectiveness of this game stem from a number of well engineered factors. The tank images have been nicely programmed into the ROM so the top view of the tank, while small, actually does appear like a top view of a real tank. Moreover, the controls used to operate the tanks faithfully and effectively imitate the type of controls used to operate all tracked vehicles where each track is separately controllable via hand-operated clutch levers. The game is further enhanced by the quality of the sounds, a factor which adds another sensory dimension to the playability of the game.

But most importantly, the designers of **Tank** have tapped into a heretofore unused reservoir of violent and competitive energy found in nearly all players. Historically, video games have employed non-violent competition between players (e.g. all paddle and driving games) or violent competition between a player and the machine (e.g. Computer Space). But no game has as effectively enabled the players to so violently and aggressively attack each other while yet remaining within the limitations of social acceptability.

1.2 Logic Symbology and Notation: The operation of all logic circuits is described using standard logic symbology and notation wherein logic functions are described using the positive logic convention. Positive logic is a system of notation where the more positive of two levels is called the HI or (1) state and the more negative is known as the LO or (0) state. All logic circuits are of the TTL family or are directly TTL compatible. The specific voltages are +2.4 volts to +5.0 volts for logic HI and 0 volts to +0.8 volts for logic LO. Signal names overscored (e.g. ATTRACT and pronounced "attract not") go LO to initiate events (active LO) and those not overscored go HI when active. Overscored signals are always at the logic level opposite their non-overscored counterparts.

Logic packages are identified in the text and in the logic schematics by their actual grid locations on the printed circuits boards (PCBs). For example, chip A3 is located at the intersection of the A column and the third row. Pins are identified by a third number. For instance, A3-1 refers to the first pin to the left of the reference notch at the end of the IC.

1.3 Two Printed Circuit Boards: Since the total number of logic packages in this game is so large, the circuitry has been incorporated into two separate printed circuits boards to facilitate the manufacturing process. However, package location numbering is continuous from PCB I to PCB II, so we assume there is only a single PCB for the discussions in the following text and will not refer to a specific component being on PCB I or II. The computer contains a total of 12 package columns (A through N) and fifteen rows, where rows 1 through 6 appear on PCB I and rows 7 through 15 appear on PCB II.

1.4 Glossary of Signals:

ATTRACT: Must be LO to enable play mode functions (3.5).
AUDIO OUT 1: First player's final sound output (16.9).
BLAST 1: Two small shapes rapidly alternated to produce explosion video at end of shell travel (15.8).
BLO-UP 1: Timed pulse during which the exploded aspect of the tank is displayed (5.5).
BOOM: Boom sound waveform used in common for both players (16.7).
BOOM COM: Timed pulse during which the explosion video is displayed and boom sound occurs (16.4).
BOUNCE: 1: Pulses HI and causes first player's tank to be bounced backwards slightly if it encounters a mine or the other player's tank or shell (7.4).
CLOCK: 14 MHz sine wave used to synchronize the entire computer (4.2).
COIN: Pulses HI when the coin is deposited (3.3).
COMP SYNC: The combination of both the horizontal and vertical sync pulses (4.13).
D0-D4: Both player's multiplexed tank rotation counts (9.2).
EXPL 1: Timed pulse during which the explosion video is displayed (7.2).
FIELD: Mine location information (11.2).
FIRE 1: Timed pulse which controls length of shell travel and when shell explodes (7.2).
FLASH: Inverts tank image within its window to generate the blown-up aspect of the tank (5.6).
GNE: Rises HI to flash score number so players are aware game-end is near (3.8).
G01: Pulses HI more frequently as tank velocity increases (6.3).
HA1-HD1: First player's horizontal motion codes (14.3).
HBLANK: 32H wide pulse occurring at the end of each half-line (4.6).
HCOUNT: Two LO-going pulses at the beginning of each half-line and used in motion circuitry (4.7).
HINFO: HI for 128 clock pulses at the beginning of each line (4.8).
HMCE: Loads new code into shell motion counters and clocks shell control circuit (5.4).
HRESET: Resets horizontal sync chain on 451st clock pulse (4.5).
HRST1: Resets first player's tank to horizontal starting position (5.3).
HSYNC: LO-going pulse between 452H (0H) and 32H which is further processed before synchronizing the horizontal oscillator of the TV monitor (4.7).
LDH1A & LDH1B: Staggered set of 16H wide LO-going pulses separated by 16H which control the loading of ROM information into the shift registers prior to display (13.2).
MEH & MEV: Horizontal and vertical boundaries of the minefield window (12.3).
MINE: This signal contains only those mines not yet exploded (12.4).
MINEFIELD: Rectangular window in the center of the CRT which determines how the minefield is positioned (12.3).
MINE MATRIX: Actual mine shapes (12.2).
MTK1: Pulses HI when a player drives his tank into a mine (12.4).
NOISE: Unprocessed white noise waveform used to develop the boom and shot sounds (16.5).

OOB: Defines outside edge of playfield perimeters (5.2).
PFLD: Prevents tank information from being loaded during the playfield and score displays (10.4).
PLAYFIELD LOAD: Series of thin vertical lines which load playfield data prior to display (10.3).
PLAYFIELD VIDEO: Serialized playfield, minefield and score display information (11.2).
RESET 2: HI between 708H and 904H (5.1).
S2H1-S8H1: Second, third and fourth output bits of first player's horizontal shell motion chain (15.3).
SCORE LOAD: Loads score numbers prior to display (10.2).
SCRA-SCRF: Both player's score information multiplexed together (9.2).
SCR1A-SCR1F: Binary equivalent of the first player's score (8.2).
SHELL 1: First player's final gun shell video (15.7).
SHOT: Shot sound waveform (16.6).
SHOT COM: Timed pulse used to limit the duration of both player's shot sounds (16.3).
SRS 1: Positions shell in gun before firing and prevents firing of a second shell while first is in flight (15.6).
START: Pulses HI after the first or second coin depending on setting of the coin option switch (3.4).
TANK 1: First player's final tank video (14.10).
TM1: Rate signal used to clock out the sequential aspects of rotating tank (5.6).
VA1-VD1: Vertical tank motion code (14.3).
VIDEO OUT: Final output of computer containing all video information and both sync pulses (11.2).
V INFO: HI for all lines between 80V and 512V. Used to address ROM, among other functions (4.12).
V RESET: Resets vertical sync chain after 521 half-lines (4.10).
VRST1: Resets first player's tank to the vertical starting position (5.3).
V SYNC: Occurs between 521V (0V) and 8V and synchronizes vertical oscillator of TV monitor (4.11).
WINDO 1: The 16H by 16V window into which the tank image is displayed (14.9).
02-04: Both player's multiplexed tank motion outputs (9.2).
102, 103, 104: Second, third and fourth bits of the first player's vertical tank motion chain (14.8).
1D0-1D4: Binary rotation number corresponding to one of the 32 different tank aspects (6.2).
1H, 2H, 4H . . . 256H: Horizontal submultiples of CLOCK used in the development of many other signals (4.4).
1V, 2V, 4V . . . 512V: Vertical submultiples of HBLANK (4.9).
2⁰-2⁷: Parallel ROM outputs (9.1).
452H: Occurs at the end of each half-line and divides the CRT in half (4.5).

1.5 Test Equipment: Due to the relatively straightforward architecture of this game, only a few inexpensive test instruments are required to fully troubleshoot the computer. A VOM or DVM is used to check the harness and the power supplies. The logic probe is needed to check the digital test points and, although our logic probe data has been acquired with a Kurz-Kasch LP-520, there are many other probes just as adequate.

And, of course, the video probe is just as valuable for examining the video development process of this game as any other video game.

Additionally, you may find a logic pulser helpful, however it is not considered absolutely essential and, if you already have a decent oscilloscope, do not hesitate to use it.

1.6 Video Probe Connection: The video probe is connected to the negative side of the video coupling capacitor C29 in the Video Summation Network (Section 11). The physical location of this component is illustrated in Figure 1.

1.7 The Game Sequence: You may use the following game sequence to verify proper computer operation.

ATTRACT & GAME START: After the last game has ended and before the new game is started, the computer remains in the *attract mode* during which time the sound, score and motion circuits are disabled. Depositing the coin(s) resets the game and enables the game's *play mode* functions. At this point, both players' scores are reset to zero, the tanks are positioned in their respective starting areas and any exploded mines are replaced. Additionally, the controls become live, the sound circuits are enabled and the game timer begins counting down.

TANK CONTROL: As mentioned before, the steering and acceleration parameters of this game follow those obeyed by all tracked vehicles, where dual *joysticks* control all tank movements. When both sticks are pushed forward, the tank accelerates slowly in the forward direction. Pulling both sticks back quickly brakes the tank and it comes to an abrupt stop. The degree of acceleration increases in direct proportion to how long the joysticks are in the forward position, however the tank will continue to travel at the last velocity when not accelerated or braked. Turning is accomplished by braking one "track" while accelerating the other. In other words, to turn in the clockwise direction, the right stick must be pulled back and the left one pushed forward. The tank motor sound changes in both rate and modulation as the tank picks up forward velocity, however at a dead stop a distinct motor idling sound should still be audible. Driving the tank into a playfield wall (the square white perimeter) or a playfield obstruction (the white objects within the playfield walls) causes a backwards bounce and a cessation of forward velocity.

THE FIRING SEQUENCE: The shell is fired simply by pressing the fire button on the right joystick which causes the appropriate tank to emit a small, rapidly travelling square which is accompanied by a realistic *shot* sound. The shell travels across the CRT until it strikes an object or simply runs out of time whereupon it explodes into a number of smaller squares. Shell explosion is accompanied by the *boom* sound. Since the next shell cannot be fired until the first has exploded, the firing rate is directly proportional to target distance. Whenever the shell strikes the enemy tank, the successful player is awarded one point and his tank is rotated one aspect so he cannot maintain accurate fire. Additionally, the hit tank image reverts to the *destroyed* or *blown-up* mode for a short period of time and the image itself is bounced backwards slightly. If a tank is hit by a succession of shells in such a way that it is driven through one of the playfield perimeter walls, it will be reset to the start-game position at the instant it encounters the outside boundary of the playfield wall.

THE MINEFIELD: If a player accidentally or intentionally drives his tank into one of the mines, the tank will revert to the blown-up aspect for a short period of time, the expended mine will be removed from the field for the duration of the game and the opposing player will be awarded one point. Mines cannot be hit and exploded by a shell.

END-GAME: The game continues in this fashion until the end of the game nears, at which time the score numerals begin to flash rapidly to indicate in lieu of a displayed game timer that end-game is at hand. When end-game does in fact arrive, the tanks are frozen in their last positions, the controls become dead and the sound circuits are silenced.

1.8 TV & PCB ADJUSTMENTS: Periodic adjustment of your tank game is necessary as a maladjusted game will discourage potential players. These adjustments fall into four groups; (a) *Customer TV* monitor adjustments, (b) *Qualified personnel TV* monitor adjustments, (c) *Customer personnel PCB* adjustments.

1.8a Customer TV Monitor Adjustments: These adjustment procedures are performed like those of any other TV monitor receiver.

- **BRIGHTNESS:** Brightness is adjusted before contrast. Adjust for a light or medium grey playfield background.
- **CONTRAST:** Adjust so that the white images are as bright as possible without being blurred.
- **HORIZONTAL HOLD:** Adjustment is indicated only if the picture is slightly off center horizontally, if the images appear warped or if the entire picture is broken up into a series of diagonal lines. Adjust for a stable, horizontally-centered picture.
- **VERTICAL HOLD:** Since this game uses a fully interlaced raster scan, the vertical sync of the monitor must be finely adjusted using the vertical hold adjustment. Adjustment is indicated if the picture appears to be rolling up or down, or if the images on the right or left half of the CRT are fluctuating excessively. First, adjust the vertical hold coarsely until the entire picture is stabilized and centered. Then, by turning the knob in very fine increments, adjust vertical sync so fluctuation of the images is kept to a bare minimum.

1.8b Qualified Personnel TV Monitor Adjustments: The following adjustments are best performed by those of you who are familiar with the maintenance of TV monitors. These adjustments have all been accurately performed by the factory prior to shipping and should not require adjustment for an extended period of time.

- **YOKE:** If yoke adjustment is indicated, adjust both yoke rings simultaneously for optimum centering of the image area within the CRT.
- **MONITOR +5 VOLT SUPPLY:** This supply is used only to power the coil of the coin counter and maladjustment or failure will not otherwise affect the computer. A 1K trimpot is located on the power/audio PCB behind the power transformer on the left side of the monitor. Measurement should be taken at the computer PCB to compensate for any voltage drop which might occur.
- **REGULATOR ADJUSTMENT:** First, adjust the horizontal and vertical hold until the display is fully synchronized. Then, connect a precision voltmeter to any of the 73-volt test points indicated in

the *Motorola Monitor Manual* and adjust regulator control R74 for an output of exactly 73 volts. **CAUTION:** Do not run the regulator control through its range or the monitor may be damaged. Only a slight turn of the trimpot should be necessary for proper adjustment.

1.8c Customer PCB Adjustments: The locations of the adjustments are indicated in Figure 1.

- **25¢/50¢ ADJUSTMENT:** This adjustment is located on PCB I and is performed by changing the position of the slide switch located at PCB position F6. This adjustment allows the operator to choose between two settings: 25¢ per "short" game and 50¢ per "long" game. The two positions are clearly marked on the PCB and the recommended setting is 25¢.
- **1ST PLAYER VOLUME:** Turning this trimpot clockwise increases the volume of all the first player's sounds. Adjustment should be set to the preference of the location in which the machine is operated.
- **2ND PLAYER VOLUME:** Adjust the same as for the first player.
- **GAME TIME:** Turning this trimpot increases or decreases the total length of the game. Be aware that total game time varies with the setting of the 25¢/50¢ switch.
- **WHITE SHELL RANGE:** This trimpot adjusts the total amount of white shell travel. To adjust, line up both tanks and adjust white shell travel so it equals black shell range.

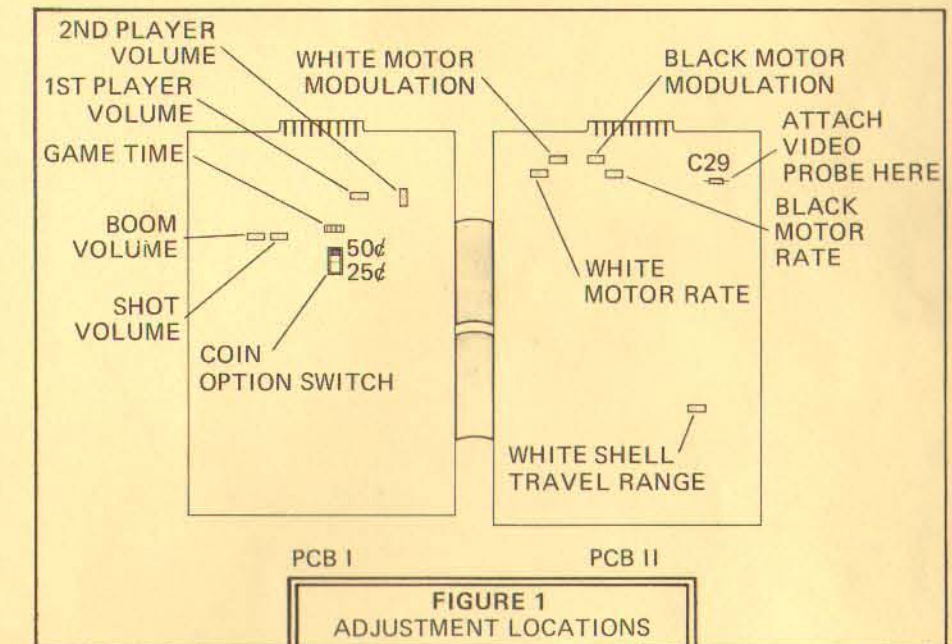

1.8d Qualified Personnel PCB Adjustments: These adjustments should only be performed by persons familiar with the maintenance of video games.

- **ANTENNA WIRE:** Trimming this wire adjusts the sensitivity of the static discharge system. Please be aware that the adjustment will depend to a certain degree upon the environment in which the machine is located. *Trimming* a bit off the wire will *decrease* the

sensitivity of the discharge system while *adding* a length of wire will *increase* the sensitivity of the circuit. Adding is indicated if players are able to obtain free games by inducing static discharges. Trimming is indicated only if the machine disables game credit during the game.

- **SHOT VOLUME:** Both the shot and boom sounds are generated in common to both players and should be adjusted prior to final volume adjustment. Adjust the shot sound volume to the preference of the location.
- **BOOM VOLUME:** Adjust this sound output to the general level of of the shot sound.
- **MOTOR SOUND RATE:** The motor sound rate is adjusted separately for each player. Adjust for a slow and realistic motor sound at idle.
- **MOTOR SOUND MODULATION:** The motor sound modulation is also adjusted separately for each player. Adjust so motor sound is deeply pitched and realistic.
- **PLAYFIELD SELECT:** The playfield display may be changed by soldering a jumper wire between D9-6 and GND.

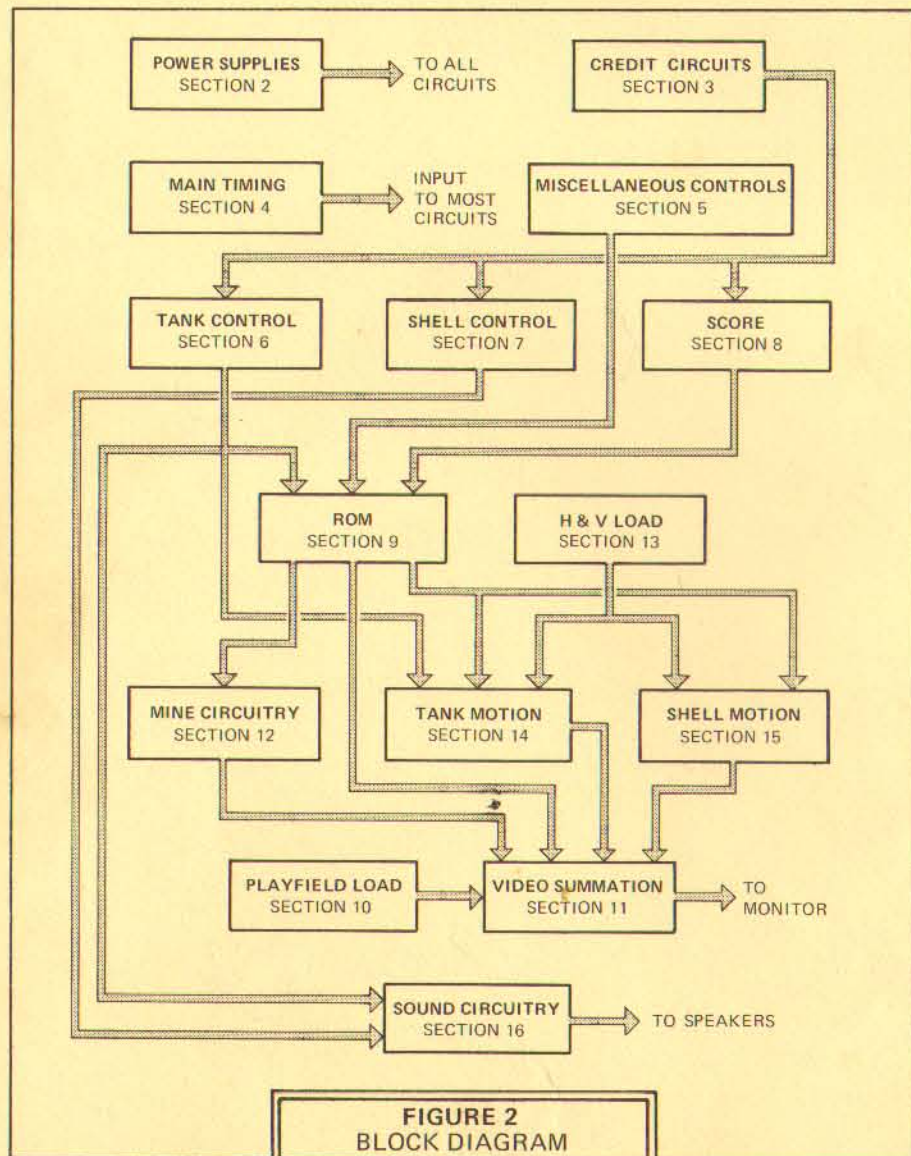

FIGURE 2
BLOCK DIAGRAM

1.9 Computer Architecture: The general design of Tank is quite straightforward and easy to understand if you are familiar with previous Atari and Kee games. It can be visualized as an integration of ideas from Computer Space, Gran Trak and Qwak. The tank and shell control circuitry is quite analogous to the control of the rocket and missile in Computer Space, however a 16K ROM generates the images in much the same way the video in Gran Trak is produced. But, although the ROM itself stores information similar to that of Gran Trak, the control of the ROM is more comparable to the address scheme of Qwak.

SECTION 2

THE POWER SUPPLIES

2.1 Functions: As is common practice with multi-board TTL computers, there is a separate +5 volt supply for each PCB. This balances and distributes the load and minimizes transients. Since the +12 and -12 volt

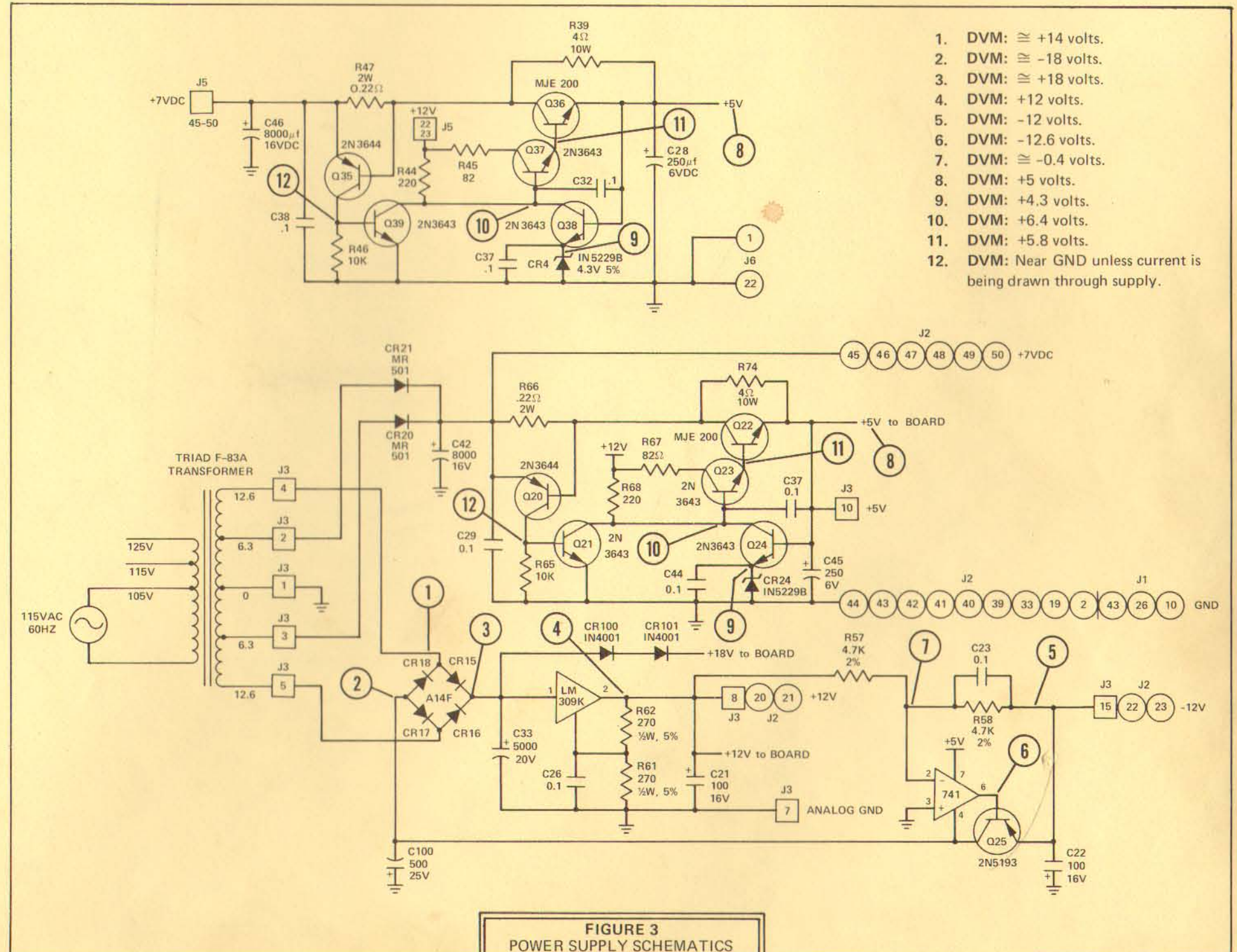

FIGURE 3
POWER SUPPLY SCHEMATICS

1. DVM: \cong +14 volts.
2. DVM: \cong -18 volts.
3. DVM: \cong +18 volts.
4. DVM: +12 volts.
5. DVM: -12 volts.
6. DVM: -12.6 volts.
7. DVM: \cong -0.4 volts.
8. DVM: +5 volts.
9. DVM: +4.3 volts.
10. DVM: +6.4 volts.
11. DVM: +5.8 volts.
12. DVM: Near GND unless current is being drawn through supply.

supplies are not heavily loaded, they are used in common to both boards. The +5 volt supply powers all the TTL circuitry and the +12 and -12 volt supplies are used for the sound circuitry and the ROM.

2.2 The +5 Volt Supplies: Although the schematics for the two +5 volt supplies may initially appear different, in reality they are identical electrically and only appear dissimilar because two draftsmen drew the schematics.

Both supplies are fully regulated and capable of approximately 3 amps. Additionally, these supplies have been designed with built-in current limiting in case of overload. The following analysis is referenced to the supply located on PCB I (Figure 3).

The supply follows a common scheme wherein a pair of differential transistors sense voltage and load and drive a pass transistor through an amplifier. Initially, the 6.3 VAC waveform from the transformer secondaries is full-wave rectified by CR20 and CR21 and filtered by C42 so the resulting DC waveform is pulsating about the 7 volt level. Q21 and Q24 form the differential pair which controls the emitter-follower amplifier transistor Q23 which is the device that actually operates pass transistor Q22. Q20 performs the current limiting function.

The sub-section formed by CR24 and Q24 controls the voltage with respect to load. If the output voltage should rise above the +5 volt level, CR24 conducts and Q24 starts to draw current from the base of Q23 thereby turning off Q23 which shuts off pass transistor Q22 and reduces the voltage. Q20 performs the current limiting feature in conjunction with Q21. If more than 3 amps are drawn through R66, the base-emitter junction of Q20 is forward biased and Q20 then conducts which pulls up the base of Q21. This causes Q21 to conduct and it "robs" base current from Q23, shutting it off and thereby limiting current to a safe level.

2.3 The +12 & -12 Volt Supply: This supply is fully regulated, however it is not fully current-limited. Initially, the 12.6 volt windings of the transformer are full-wave rectified by the bridge rectifier composed of CR15, CR16, CR17 and CR18. This results in a pulsating +18 volt DC waveform at the junction of CR15 and CR16 and a -18 volt pulsating DC level at the junction of CR17 and CR18 (Note: All levels referenced to GND).

The +18 volt line is filtered by C33 before entering the input of the LM309K integrated voltage regulator. This regulator is offset from ground by R61 and R62 so the output voltage is actually +12 volts regulated DC with respect to GND. This waveform is further filtered by C21 to eliminate slow transients.

The -18 volt line is first filtered by C100 and then entered at the collector of pass transistor Q25. R57 and R58 form a voltage divider network where the junction is connected to the inverting (-) input of the operational amplifier. This amplifier controls the base of the pass transistor (hence the output voltage as well) in proportion to any imbalance at the junction of the voltage divider network.

SECTION 3

THE CREDIT CIRCUITRY

3.1 Functions: This collection of loosely-related sub-circuits performs a number of significant credit functions and generates several important signals used throughout the computer. Its primary functions are to detect the deposit of a genuine coin, advance the coin counter, start the game, time the length of play and end game credit at the appropriate time. In addition, this circuit also performs certain anti-cheat functions and indicates when game-end is near. The important signals produced are COIN, START, ATTRACT and GNE.

3.2 The Coin Counter: If either coin switch is closed by the deposit of a coin, edge connector pin 12 or 14 will be grounded and brought to a logic LO level. This LO enters one of the switch debouncers constructed from inverters B6 and results in a HI from B6-6 or B6-10 which in turn produces a LO from D6-10. This LO is inverted at A6 to provide current for Q40 which turns on. Since the emitter of Q40 is connected to the base of Q41, Q41 is also turned on so that current flows through the coil from the +5 volt TV monitor supply and operates the armature of the coin counter.

The monitor power supply is used because there is quite a bit of inductive kickback from the counter coil and using a separate supply prevents any spikes from entering the +5 volt supply used for the logic circuitry.

3.3 The Coin Circuit: If the game has ended, ATTRACT is LO so there are two LOs at pins 11 and 12 of D6 when the coin is deposited. The HI resulting from D6-13 provides a HI D input to J6 and also enables J4 and J6. Both these flip-flops are clocked by 128V so the signal from D6-13 must remain HI for at least 128V (about 2 ms) at the first flip-flop before J6-9 can go HI. It must also stay HI for an additional 128V at J4 before its output can go HI. Therefore, a game will start only if one of the coin switches makes for at least 256V or 4 ms. This has been specifically designed this way so that incidental or player-induced vibration of the game cabinet which actuates the coin acceptor trip wire will not produce a free game. The HI output of J4 is known as COIN and its function is simply to indicate to the rest of the computer that a valid coin has been deposited. COIN clocks E6 which is used only when the game is conditioned for 50¢ play.

3.4 The 25¢/50¢ Switch: When the coin switch is set to the 25¢ position, pin 3 of D6 is grounded to a logic LO level. When the coin is deposited, COIN drops LO, producing a HI from START which in turn causes ATTRACT to rise HI and enable the game's play mode functions. However, if the switch is set to the 50¢ position, there are two different ways that two coins may start a game. In other words, two coins may be dropped through the same or different chutes sequentially or two coins may be dropped through both chutes simultaneously.

But for either of these two ways to work, E6 must be enabled by a HI at its reset line (pin 13). This can only occur if both inputs to N6 are LO so that N6 can then output the HI enabling E6. As long as no static discharge is occurring (more about this in a moment), N6-8 will be LO.

Since the game has not yet started, ATTRACT is LO providing the other LO input to N6. When the game ends, ATTRACT returns HI and clears E6 to prevent any credit from be registered.

If two coins are deposited sequentially, the result is as follows: when the first coin is deposited, COIN rises HI but nothing happens until the coin switch returns to its normal position at which time J4 and J6 are reset and E6 toggles. This results in a HI from E6-3 which is inverted LO at N6-3. If the coin adjustment switch is set to the 50¢ position, this produces a LO at D6-3 and this node remains LO. Now, when the second coin is deposited, COIN also drops LO providing two LOs at D6 and START rises HI to begin the new game.

If the coins are dropped in both chutes simultaneously, N6-4 goes HI producing a HI at N6-2 which then results in a LO at N6-1 and at D6-3. Because a coin has been deposited, COIN has dropped LO which provides a LO to D6-2. Since there are not two LOs at D6, START rises HI and allows the game to begin.

3.5 Attract: The signal ATTRACT controls the play mode functions throughout the computer and when this signal is HI, the player's controls, etc. are disabled. The control to ATTRACT is performed at flip-flop E6 where three events have a bearing on its operation. First of all, START must rise HI to toggle the flip-flop. Second, there can be no static discharge. Finally, the flip-flop must be enabled by the output of the game timer circuit.

When the coin is deposited, START rises HI and is sent to two places. First, it is inverted so it drops LO at pin 2 of the 555 timer which starts C25 charging through the play-time trimpot and R53/R54 if in the 25¢ mode or just R54 if in the 50¢ mode. Therefore, as START rises HI, the timer output (pin 3) also rises HI. At the same time, START places a HI at E6-8 and ATTRACT rises HI 128V later to enable the game. At the end of the game, the timer output returns LO which produces two LOs at D6-5 and D6-6 along with the LO from ATTRACT. The result is a HI from D6-4 which is clocked through flip-flop E6 128V later to produce a LO ATTRACT and a HI ATTRACT, thereby ending the game. Since ATTRACT has gone HI, D6-4 drops LO and since START at E6-8 is LO, the flip-flop latches in the last configuration until the next coin is deposited.

3.6 The Anti-Static Circuit: The function of this circuit is to prevent players from obtaining free games by inducing static discharges into the credit circuit. Without the static system, a large enough discharge would otherwise be interpreted as a coin deposit signal. The inclusion of the anti-static circuit prevents credit from being registered even though transients may in fact get into the credit circuit.

The *antenna* is simply an unterminated wire used to sense the release of a static discharge. Since the signal picked up by the antenna is so weak, it must first be amplified by Q1 to operate the circuit. If a discharge is released, Q1 turns on and current flows through this transistor causing N4-1 to go to a logic LO level, hence N4-2 rises HI and N4-4 drops LO. The HI at N4-2 is connected to N6-8 which resets the start flip-flop E6 and prevents a HI START. Simultaneously, the LO from N4-4 clears the attract flip-flop E6 and turns the game off if there is one in progress.

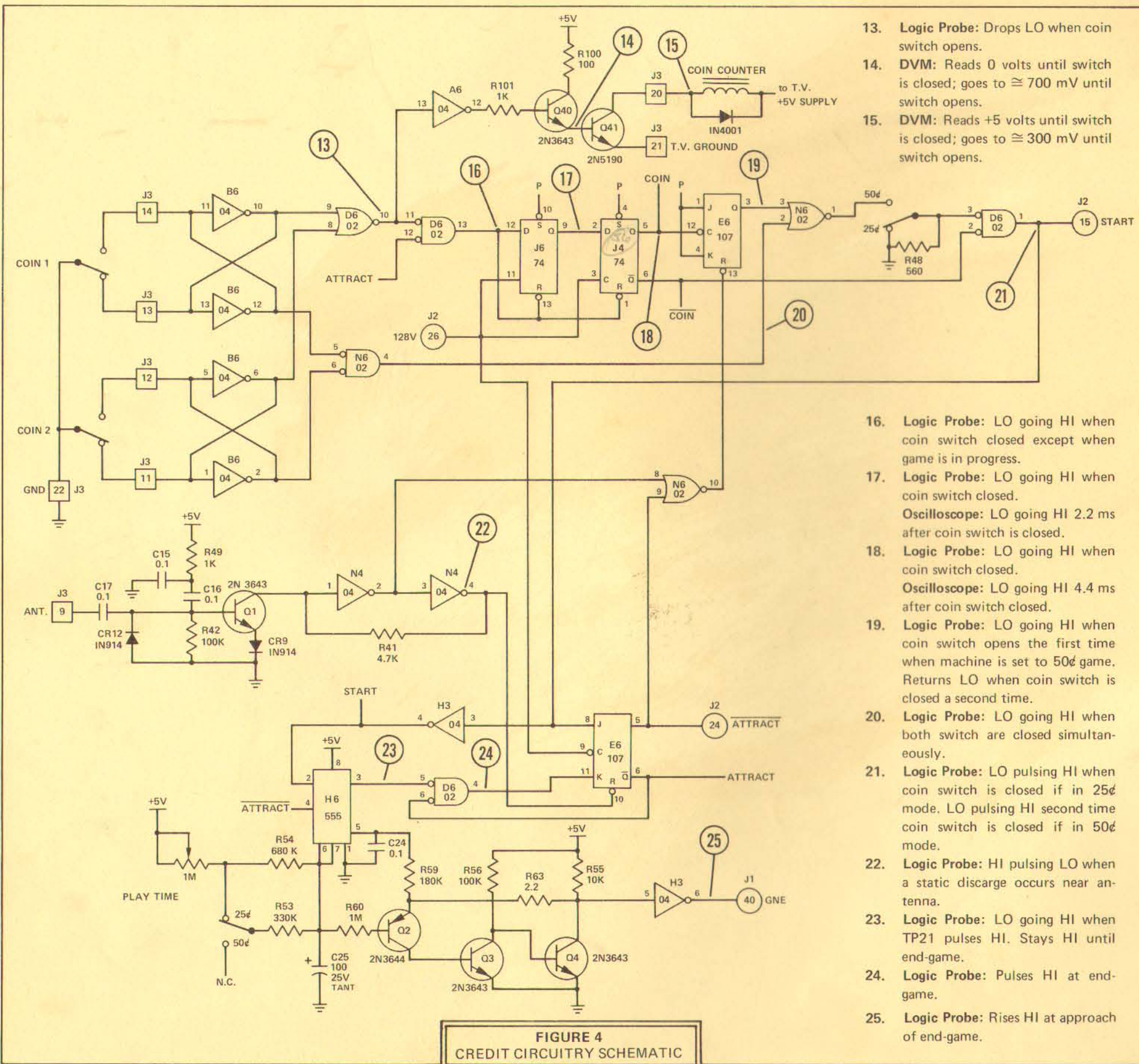

- 13. Logic Probe: Drops LO when coin switch opens.
- 14. DVM: Reads 0 volts until switch is closed; goes to ≈ 700 mV until switch opens.
- 15. DVM: Reads +5 volts until switch is closed; goes to ≈ 300 mV until switch opens.
- 16. Logic Probe: LO going HI when coin switch closed except when game is in progress.
- 17. Logic Probe: LO going HI when coin switch closed.
Oscilloscope: LO going HI 2.2 ms after coin switch is closed.
- 18. Logic Probe: LO going HI when coin switch closed.
Oscilloscope: LO going HI 4.4 ms after coin switch closed.
- 19. Logic Probe: LO going HI when coin switch opens the first time when machine is set to 50¢ game. Returns LO when coin switch is closed a second time.
- 20. Logic Probe: LO going HI when both switch are closed simultaneously.
- 21. Logic Probe: LO pulsing HI when coin switch is closed if in 25¢ mode. LO pulsing HI second time coin switch is closed if in 50¢ mode.
- 22. Logic Probe: HI pulsing LO when a static discharge occurs near antenna.
- 23. Logic Probe: LO going HI when TP21 pulses HI. Stays HI until end-game.
- 24. Logic Probe: Pulses HI at end-game.
- 25. Logic Probe: Rises HI at approach of end-game.

3.7 The Game Timer: The amount of play-time is determined both by the adjustment of the game time trimpot and by the setting of the 25¢/50¢ switch. If the switch is in the 25¢ mode, the play time may be adjusted from 24 seconds to about 134 seconds. However, if set to the 50¢ position, the time can be varied between 75 and 185 seconds.

Capacitor C25 is the timing cap for the 555 and it causes the 555 to change states when it has charged to about $2/3 V_{cc}$. When the 25¢/50¢ switch is set to the 25¢ position, R53 and R54 are switched into a parallel configuration with a total resistance of 220K. This lower amount of resistance causes C25 to charge at a faster rate so the game ends more quickly. When in the 50¢ position, however, the capacitor must charge through 680K and the amount of play time will be lengthened. But within these two play time settings, the actual time may be varied by changing the adjustment of the play time trimpot.

3.8 Game Near End: Q2, Q3 and Q4 form a circuit which senses the approach of end-game and causes the score numbers to flash, thereby indicating to the player that end-game is imminent.

As capacitor C25 is charging, Q2 is turned on until the charge on C25 reached a level greater than $2/3 V_{cc} - V_{be}$ or 2.7 volts. At this point, Q2 shuts off which also shuts off Q3 and turns on Q4. Hence, a LO is generated at H3-5 which is inverted to produce a HI at H3-6 (GNE). GNE (Game Near End) is taken directly to the video summation circuit where it causes the score numerals to be rapidly turned off.

SECTION 4
MAIN TIMING

4.1 Interlaced Raster Scan: The main timing circuitry of Tank is quite analogous to that of Gran Trak for both games use a fully interlaced raster scan. While this type of scan is not particularly complicated, it must be fully understood for the operation of the sync circuitry to make sense.

Interlaced raster scan is a technique used where small images are displayed and greater resolution is required. The essential difference between this type of scan and the normal non-interlaced scan is that successive fields are laid in between each other rather than on top of one another. The result is twice as many separately displayable raster lines where each line also contains twice as many separately addressable points. Interlace is achieved by using a 14 MHz clock rate so each horizontal line can be divided in half where each half-line contains 452 clock pulses and where there are an odd number of half-lines per field.

In the interlaced scheme, the first line of the even field begins in the upper left corner of the CRT (Figure 5). The odd field, however, begins in the middle, however this point occurs at the bottom edge of the CRT (Figure 6). The odd field is started in the center of the CRT by counting an odd number of half-lines, but more about this later.

The nomenclature associated with the interlaced scan remains basically the same as for the non-interlaced version. The only significant difference is the fact that, since the fields are generated using half-lines, hori-

FIGURE 4
CREDIT CIRCUITRY SCHEMATIC

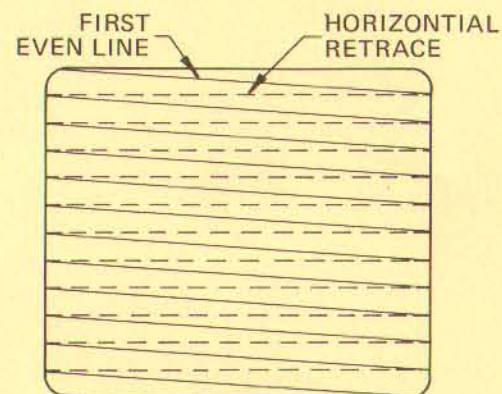

FIGURE 5
EVEN FIELD SCAN

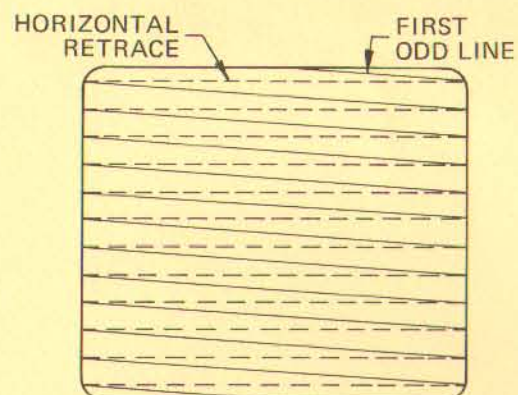

FIGURE 6
ODD FIELD SCAN

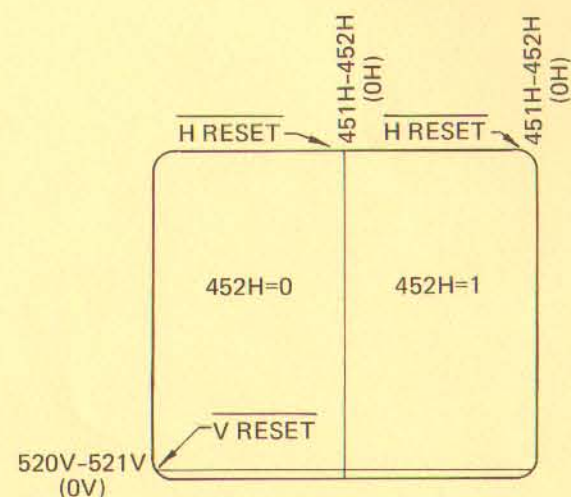

FIGURE 7
HORIZONTAL AND VERTICAL RESET

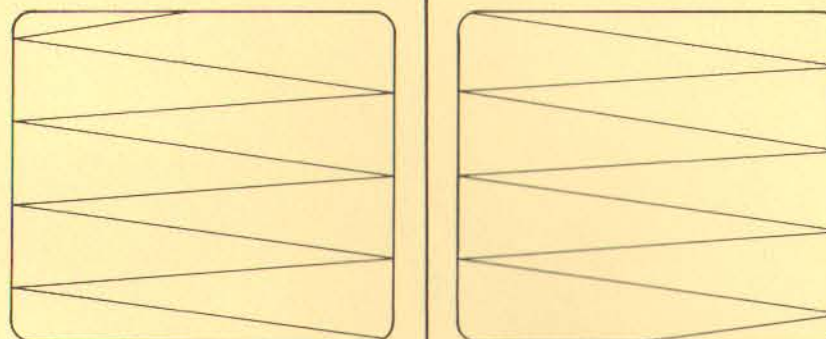

FIGURE 8
EVEN FIELD RETRACE

FIGURE 9
ODD FIELD RETRACE

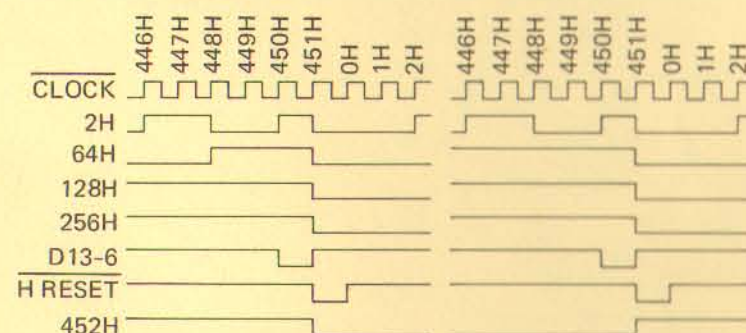

FIGURE 10
DEVELOPMENT OF H RESET & 452H

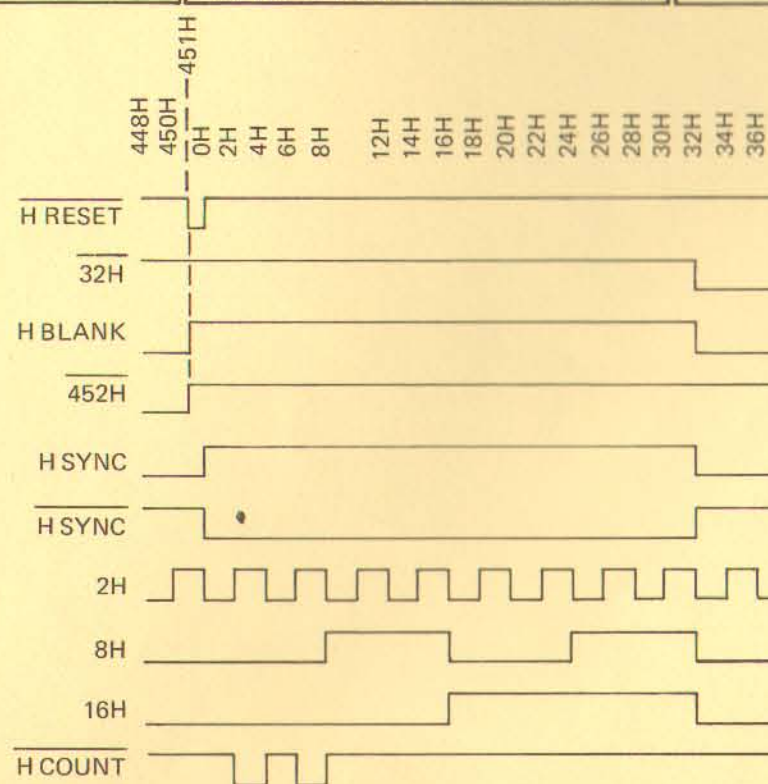

FIGURE 11
DEVELOPMENT OF H BLNK, H SYNC & H COUNT

horizontal reset occurs both in the center of the CRT and at the right edge (Figure 7). Vertical reset still occurs when the electron beam is at the end of the last line of each field. But since there are differences between the fields, vertical retrace occurs differently for each field. The even field ends in the lower right corner of the CRT and the electron beam is retraced back to the top center instead of the top left corner (Figure 8). The end of the odd field occurs in the center bottom of the CRT and the electron beam is reset back and up to the upper left corner prior to scanning the next even field (Figure 9).

4.2 The Oscillator: The Oscillator produces CLOCK, the master timing signal which synchronizes the entire computer. The crystal generates a 14.318 MHz frequency and it is kept oscillating by two closed-loop amplifiers which consist of a feedback resistor and an inverter each. The amplifiers operate out of phase with respect to each other and are coupled together with a 0.1μF capacitor. A third inverter serves as a buffer-amplifier.

Normally, the 14 MHz oscillator frequency is divided in half to 7MHz before being counted down by the horizontal sync chain. But since this game is fully interlaced wherein each line contains twice as many separately displayable points, the frequency of CLOCK must also be twice as great, hence the oscillator frequency is simply left at 14MHz.

4.3 Synchronization: The functions of the following sync circuits are primarily twofold: (1) These circuits generate submultiples of CLOCK which are used in most other circuits of the game to provide precisely timed signals used in the development of other, more complex signals where all signals have a synchronous relationship to both CLOCK and the movements of the electron beam. (2) Some of these submultiples are combined to develop sync signals which synchronize the operations of the vertical and horizontal oscillators of the TV monitor with the operation of the PBC computer.

4.4 Horizontal Main Timing: The horizontal counter chain divides the frequency of clock 2^{10} or 1024 times to produce the various submultiples of CLOCK known as 1H, 2H, 3H . . . 256H. This chain is constructed from two 9316 four-bit binary counters which provide the first eight bits and two flip-flops which provide the ninth and tenth bits. The 9316 counter is used in this circuit because it will function at the high clock rate. Ten bits are used in the chain rather than the normal nine because a full line is 904 clock pulses long.

4.5 Horizontal Reset: As mentioned before, the horizontal reset pulse in this game occurs both in the center of the CRT and at the right side so that half-lines are created (Figure 7). To generate H RESET, 256H, 128H, 64H and 2H are first added at D13 to produce a LO-going pulse at 450H (Figure 10). This pulse is clocked through flip-flop K12 one clock pulse later, hence H RESET occurs at the count of 451. Notice that this signal is connected to the reset inputs of both counters and the first flip-flop, but that it is not connected to the second flip-flop. Therefore, H RESET clears both counters and the first flip-flop so they are reset to zero on the 451st count. Since the first half of C2 is cleared, its Q output drops LO which toggles the second flip-flop. Although the flip-flop is toggled at 451, the signal is not effective at B12 until the whole chain is reset which occurs on the next, or 452nd, clock pulse. Since the signal 452H is LO on the left half of the CRT and HI on the right, this signal

divides the screen in half thereby creating the half-lines necessary to interlace the scan.

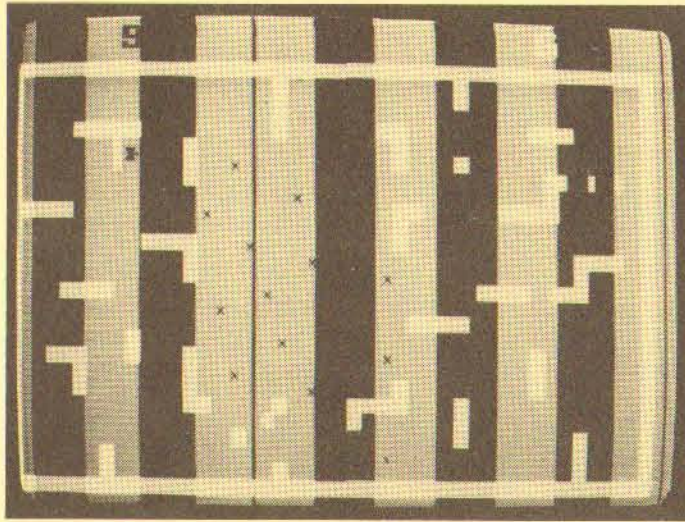

64H: This is an example of a horizontal clock submultiple and notice that the signal is reset in the approximate center of the CRT.

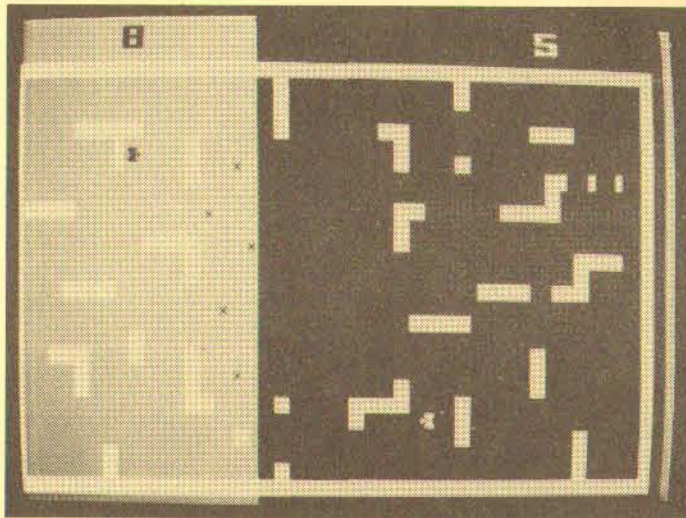

452H: This signal divides each line of the raster approximately in half to permit interlacing of the fields.

4.6 Horizontal Blanking: The developmental process for H BLANK is illustrated in Figure 11. The R-S flip-flop constructed from gates B14 is set by H RESET and reset 32H later to produce a blanking pulse 32H wide between 451H and 32H.

4.7 Horizontal Sync & H COUNT: H BLANK, 452H and H RESET are added at B12 and the result is a LO-going pulse between 452H (0H) and 32H known as H SYNC. H COUNT is developed by inverting H SYNC and adding it with the signal from B11-1 (16H·8H) and 2H to produce two LO-going pulses at the very beginning of each half-line (Figure 11).

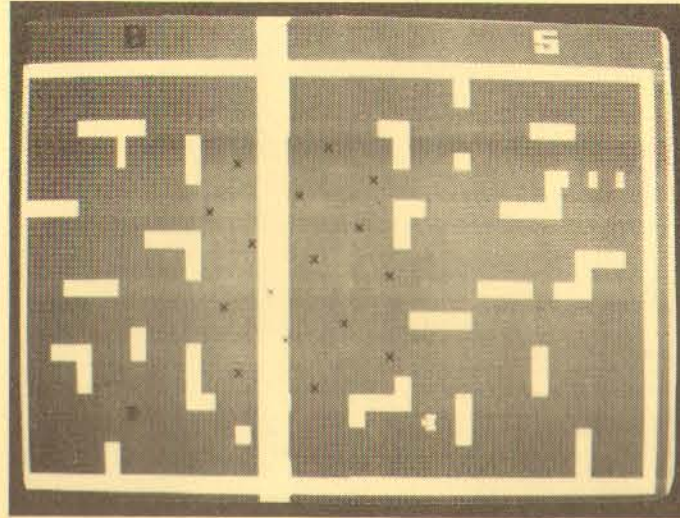

H BLANK: Horizontal blanking occurs both in the center and at the right edge of the CRT due to the interlaced scan of this game.

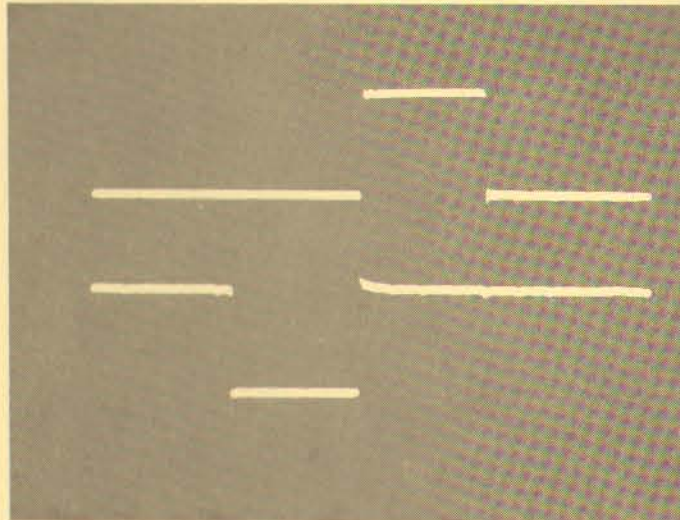

H SYNC: The actual pulse to which the monitor is synchronized (top) is compared with H SYNC (bottom). 1 us/div. 2 v/div.

4.8 H INFO: This signal is developed by the R-S flip-flop constructed from gates A13. This flip-flop is set when H SYNC rises HI and it is reset 128 clock pulses later when 128H rises HI to form a window 128H wide at the beginning of each line (Figure 13). The resulting signal is gated with H SYNC and 64H at A14 and then inverted to produce a HI-going pulse between 32H and 64H (Figure 12) which is the actual signal to which the monitor is synchronized.

4.9 Vertical Timing: The vertical timing chain is virtually identical to the horizontal except that it counts H BLANK pulses or half-lines rather

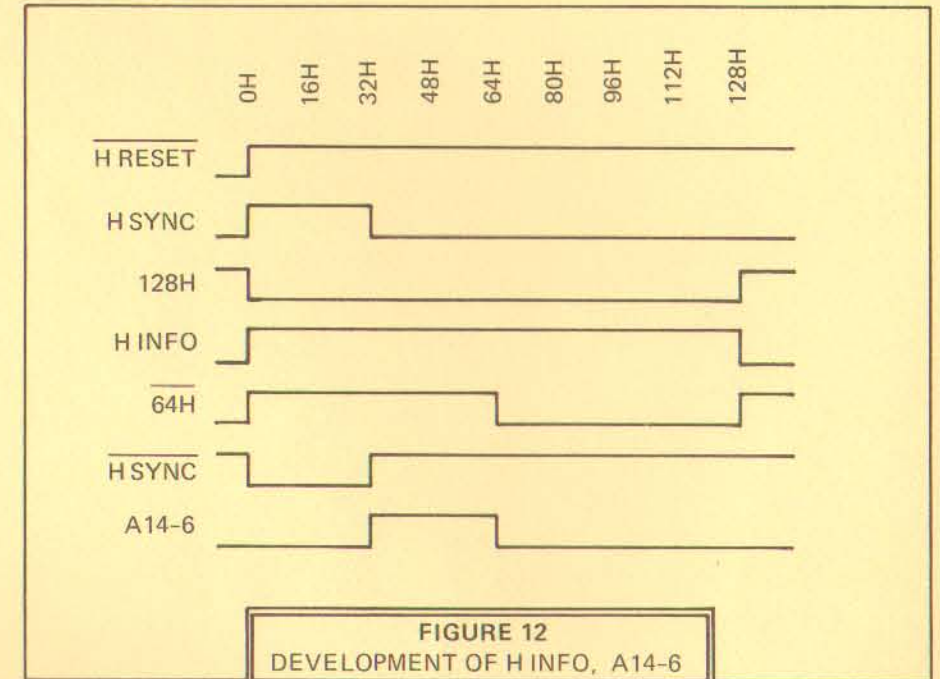

than clock pulses. Since each H BLANK pulse coincides with the termination of a half-line, the vertical timing circuit counts lines per field whereas the horizontal counts points or clock pulses per line. A vertical reset pulse coincides with the termination of each full field of half-lines (Figure 7).

This chain also has ten bits because it must count a total of 521 half-lines per field rather than the usual 262 full lines found in most non-interlaced games. This counter chain is constructed from 7493s which are fast enough for the slower frequency of vertical sync. These counters divide the frequency of H BLANK 2^8 times to produce the vertical submultiples known as 1V, 2V, 4V . . . 128V. The ninth and tenth bits (256V and 512V) are supplied by two flip-flops and notice that both are reset by V RESET.

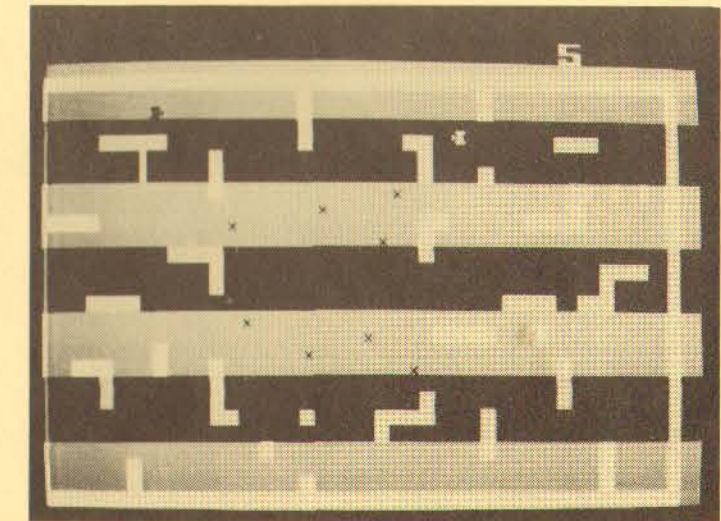

64V: This photograph illustrates the vertical submultiple 64V.

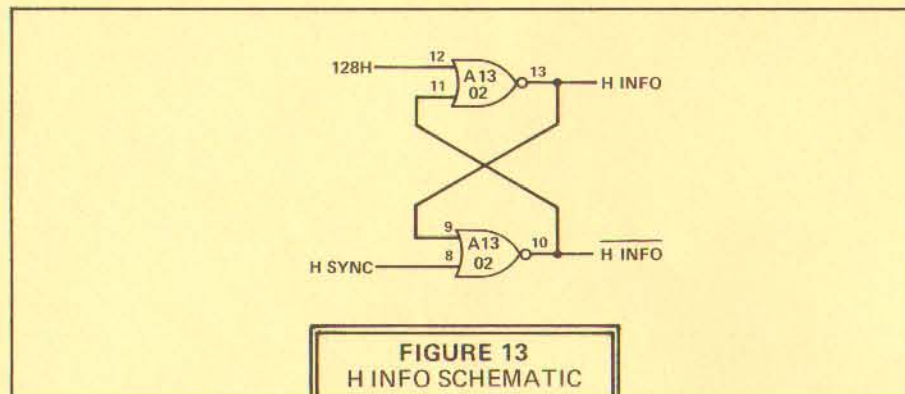

FIGURE 13
H INFO SCHEMATIC

4.10 Vertical Reset: 512V is gated with 8V to produce a LO-going pulse at 520 which is clocked through K12 by H RESET to form a V RESET pulse at 521. The reason for generating the reset on an odd number is so that the two fields may be interlaced. If an even number of half-lines were counted, the electron beam would always begin the new field in the upper left corner. By counting one extra half-line, the electron beam must begin the next field at the middle of the top edge of the CRT.

4.11 Vertical Sync: On the 521st half-line, the vertical reset pulse occurs which resets the entire counter chain and also the R-S flip-flop constructed from gates B11. This flip-flop is reset 8V later to develop a vertical sync pulse which extends from 521V (or 0V) to 8V.

4.12 V INFO: The R-S flip-flop constructed from gates J13 is set when 512V drops LO and is reset at 80V by the signal from J13-8. V INFO therefore is HI between 512V (or 0V) and 80V.

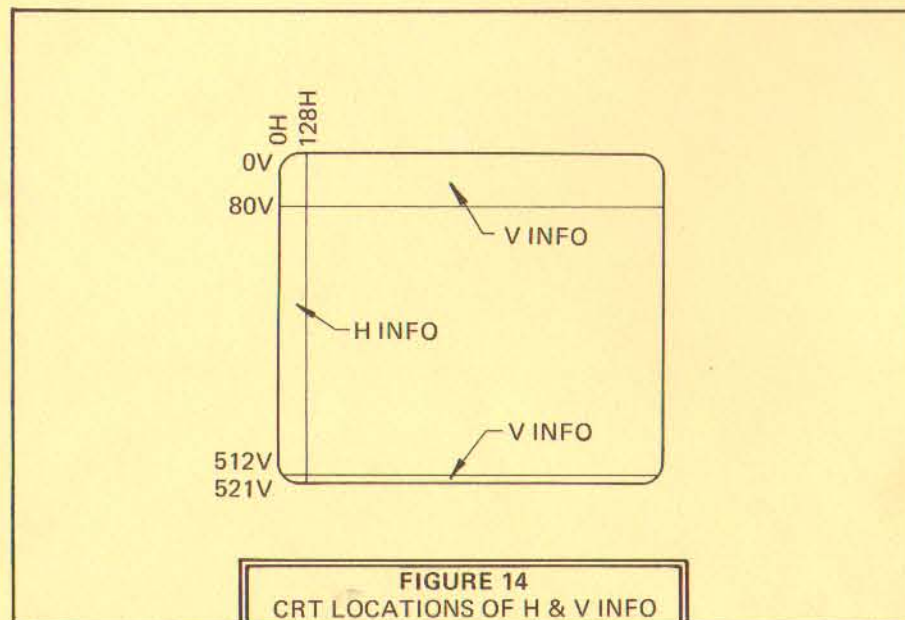
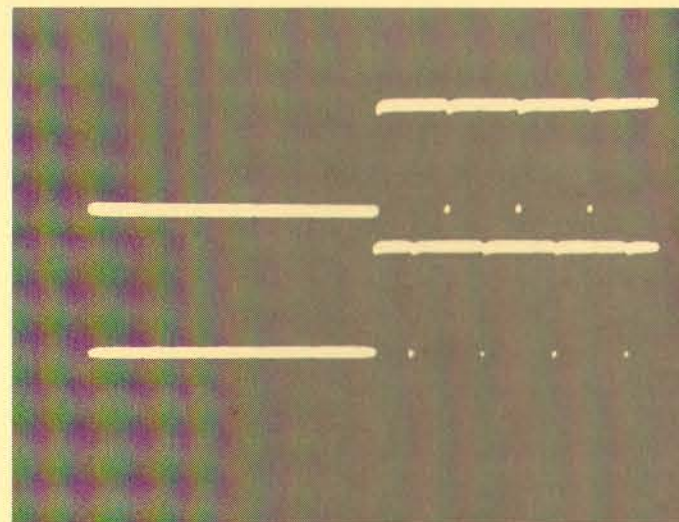

FIGURE 14
CRT LOCATIONS OF H & V INFO

4.13 Comp Sync: The horizontal and vertical sync pulses are gated together at B11. When the electron beam reaches the end of the last odd or even line, it is reset back to the top of the CRT by a process which includes four complete horizontal sweeps (Figures 8 and 9).



COMP SYNC: COMP SYNC for the odd field (top) is contrasted with that of the even field (bottom). 50 us/div, 2 v/div.

SECTION 5

MISCELLANEOUS CONTROL SIGNALS

5.1 RESET 2: This signal is used both in the development of OOB and HRST 2. Signals 452H and 256H are simply ANDed at A11 and the result (RESET 1) is HI between 708H and 904H.

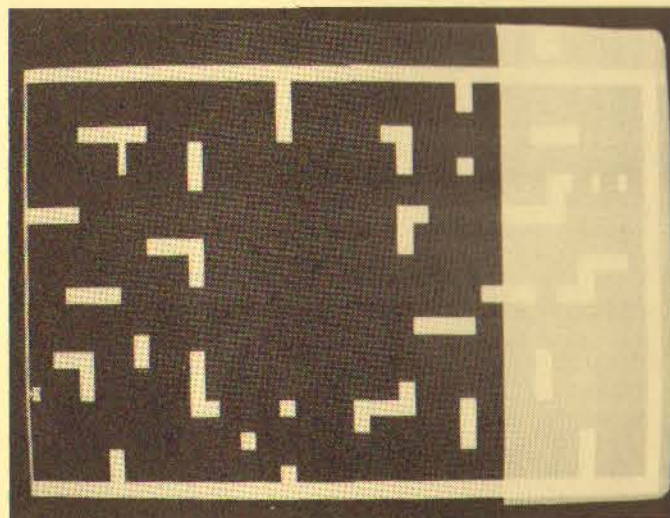

RESET 2: The light area in this photograph illustrates the time (or area of the CRT) when RESET 2 is HI.

5.2 OOB: Signal OOB (Outside Boundaries) defines that area of the CRT outside the playfield perimeter. The combination of the signals at the inputs of C13 generates a signal from C13-6 which drops LO at 160H to set the R-S flip-flop constructed from gates B13. This R-S flip-

flop is reset at 884H by the signal from D13-8 so that B13-11 is LO from 160H to 884H. This represents those areas to the right and left of the vertical playfield perimeters. V INFO is LO from 512V to 80V and its inclusion at E14 establishes the top and bottom areas outside the horizontal boundaries of the playfield walls.

5.3 Tank Resets: These two circuits develop signals which reset both player's tank images to the proper vertical and horizontal positions at the beginning of the new game. Since both player's circuits are identical, our analysis will cover only the process by which the resets for tank 1 are developed.

At the start of a new game or if Tank 1 encounters the outside playfield perimeter (which occurs only when tank 1 is blasted through the playfield perimeter wall by successive firings of tank 2 shells), L8-11 drops LO which clears flip-flops L9. H INFO rises HI at 128H and elicits a HI from HRST 1. Previously, when HRST 1 was LO, the motion counters for the first player's tank were cleared. When HRST 1 rises HI and after the motion counters have filled up, tank 1 is displayed in its reset condition. The other half of L9 works identically, except that it positions tank 1 vertically.

5.4 HMCE: This control signal is used both in the loading of the code into the shell motion counters and to clock the shell control circuit (Section 7.2). VLD 2 is simply one LDH2B pulse occurring after the V RESET pulse as illustrated in Figure 20. This signal clocks K9 so a LO appears at the D input of the other half of K9. The result is a HI from K9-9 which is clocked through the next time 452H pulses HI thereby enabling K9-9 again.

5.5 BLO-UP 1 & BLO-UP 2: These two identical circuits determine the length of time the blown-up aspect of the tank is displayed. Both circuits utilize a single 556 which is no more than two 555s in a single package. When one player's tank encounters a mine or a shell from the opponent's tank, HT 1 or HT 2 drops LO. This starts the timer which generates a timed pulse with a duration of approximately 2 seconds.

5.6 FLASH & TM1: FLASH is used to rapidly invert the tank image so the blown-up aspect is displayed when the tank is hit by a shell or encounters a mine. TM1 is the rate signal used to clock out the tank aspects when the tank image is rotated. The circuit counts V RESET pulses. It enables VLD through B12-8 for three V RESET pulses and disables VLD for another three V RESET pulses. If ATTRACT is LO (game in progress), it allows the "three on - three off" signal from B12-8 through A13 to form TM1.

SECTION 6

TANK CONTROL

6.1 Functions: The rotation and acceleration of the tank is controlled by the circuit in Figure 24. All control inputs originate in the player's joysticks and, since each tank must be capable of separate control, there must be two tank control circuits which are nearly identical. The only difference is that shell travel for the white tank is adjustable.

- 26. **Logic Probe:** HI, LO and Pulsing.
Oscilloscope: 14 MHz sine wave with period of 69.8 ns.
- 27. **Logic Probe:** HI and Pulsing.
Oscilloscope: Pulses LO every 31.4 μ s for 69.8 ns.
- 28. **Logic Probe:** LO and Pulsing.
Oscilloscope: Pulses HI every 31.4 μ s for 2.2 μ s.
- 29. **Logic Probe:** HI, LO and Pulsing.

- Oscilloscope:** Changes state every 31.4 μ s.
- 30. **Logic Probe:** HI and Pulsing.
Oscilloscope: Pulses LO every 63 μ s for 2.2 μ s.
- 31. **Logic Probe:** HI and Pulsing.
Oscilloscope: Two pulses occurring every 63 μ s having a period of 280 ns and a duration of 140 ns.
- 32. **Logic Probe:** LO and Pulsing.

- Oscilloscope:** Occurs at end of TP30 and has same width.
- 33. **Logic Probe:** HI, LO and Pulsing.
Oscilloscope: Pulses every 63 μ s for 8.9 μ s.
- 34. **Logic Probe:** LO and Pulsing.
Oscilloscope: Pulses every 16.4 ms for 31.5 μ s.
- 35. **Logic Probe:** LO and Pulsing.
Oscilloscope: Pulses every 16.4 ms

- for 220 μ s.
- 36. **Logic Probe:** HI, LO and Pulsing.
Oscilloscope: Pulses every 16.4 ms for 280 ms.
Video Probe: Light horizontal bar at the top of CRT.
- 37. **Logic Probe:** HI and Pulsing.
Oscilloscope: See CRT photo of COMP SYNC.

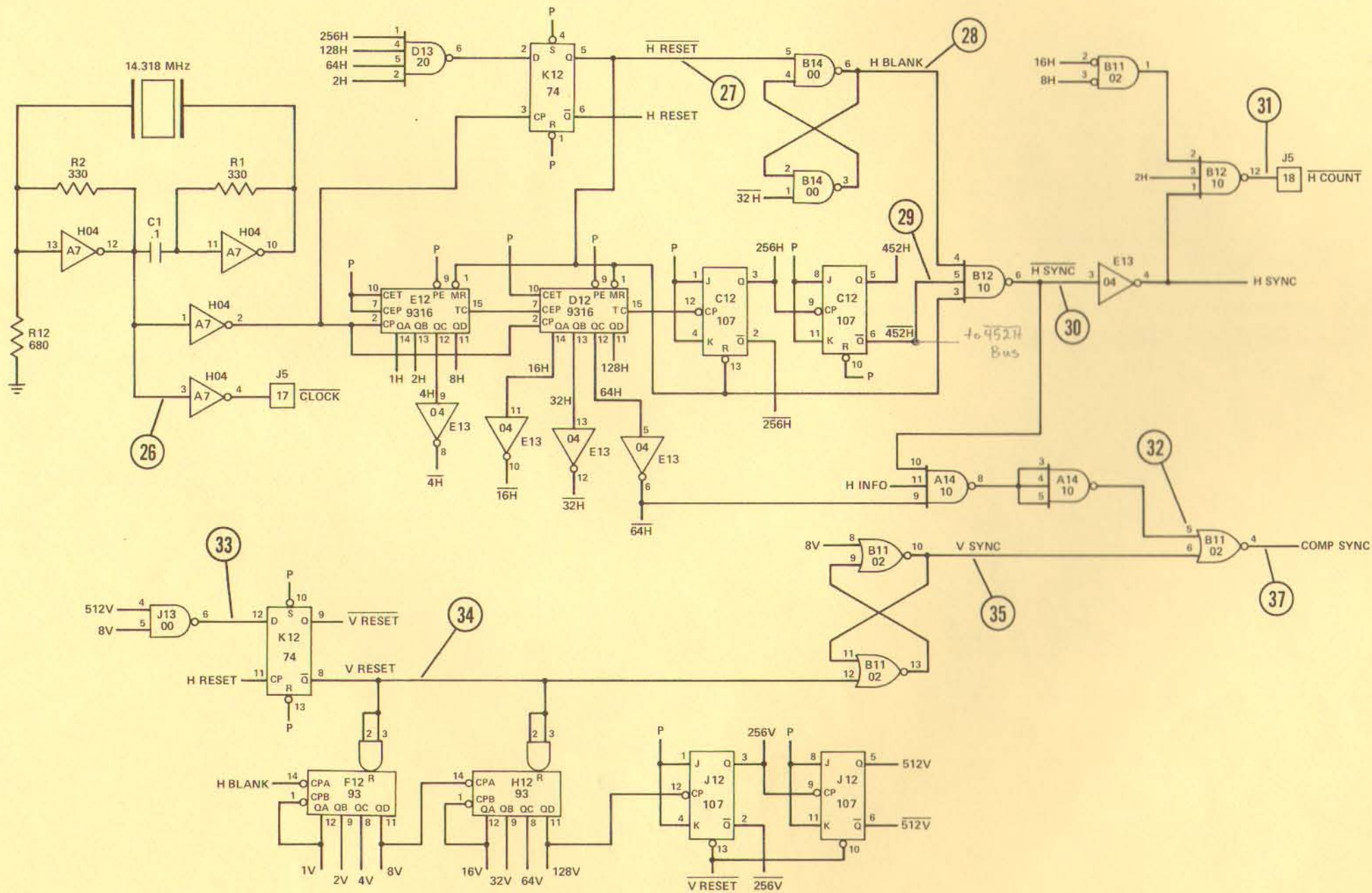

FIGURE 16
MAIN TIMING & SYNC SCHEMATIC

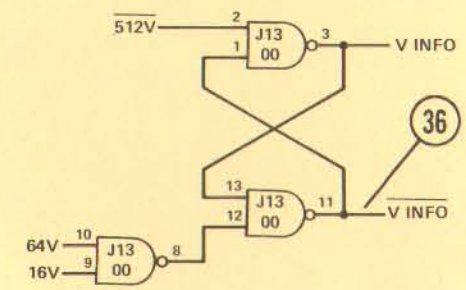

FIGURE 15
V INFO SCHEMATIC

- 40. **Logic Probe:** HI, LO and Pulsing.
Video Probe: Wide light vertical column at right edge of CRT.

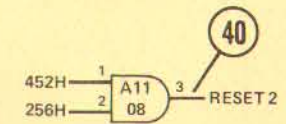

FIGURE 17
RESET 2 SCHEMATIC

- 41. **Logic Probe:** HI and Pulsing.
Video Probe: Three dark vertical columns on left side CRT.
- 42. **Logic Probe:** HI and Pulsing.
Video Probe: Dark vertical column at left of CRT.
- 43. **Logic Probe:** HI, LO and Pulsing.
Video Probe: Dark outside vertical boundaries.
- 44. **Logic Probe:** HI, LO and Pulsing.
Video Probe: Light outside boundaries.

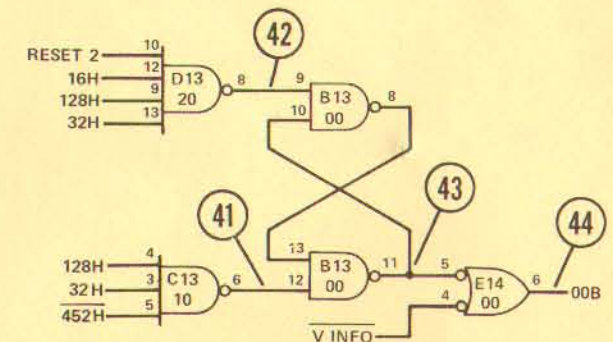

FIGURE 18
OOB SCHEMATIC

- 45. Logic Probe: HI pulsing LO when game starts or if white tank encounters TP44.
- 46. Logic Probe: Same as TP45.

- 47. Logic Probe; HI pulsing LO when game starts or if black tank encounters TP44.
- 48. Logic Probe: Same as TP47.

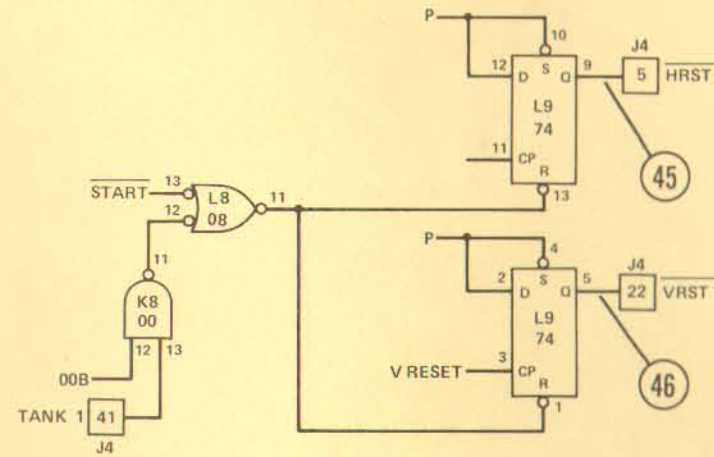
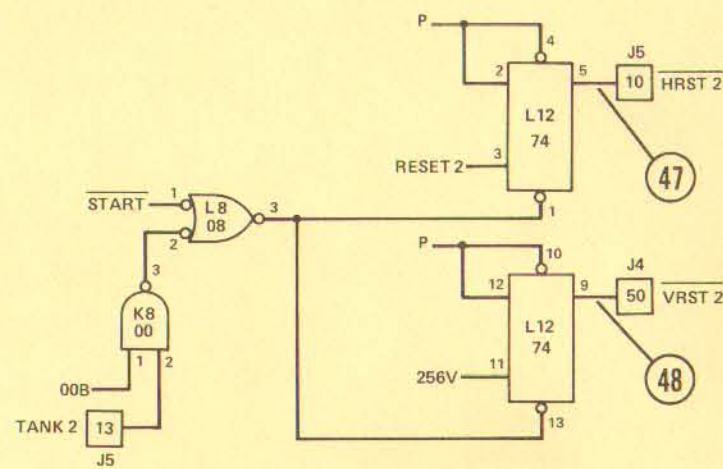

FIGURE 19
TANK RESETS

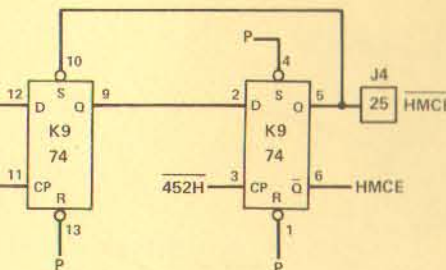

FIGURE 21
HMCE SCHEMATIC

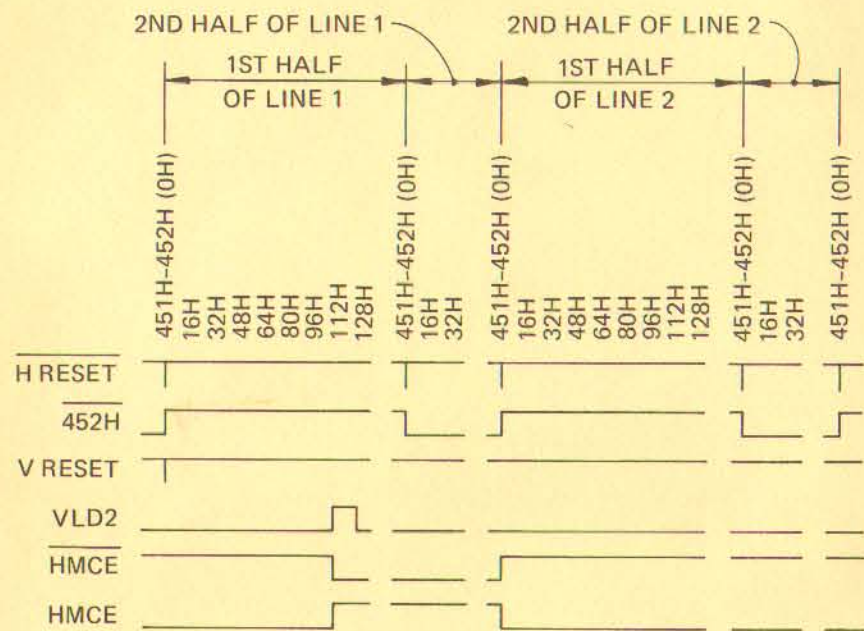

FIGURE 20
DEVELOPMENT OF HMCE

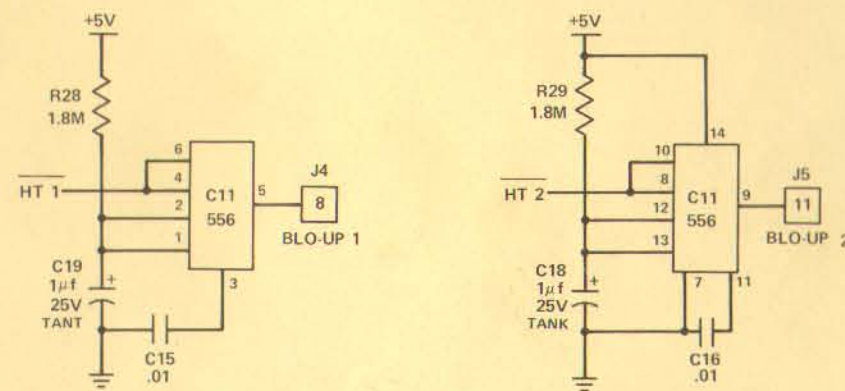

FIGURE 22
BLO-UP 1 & BLO-UP 2 SCHEMATICS

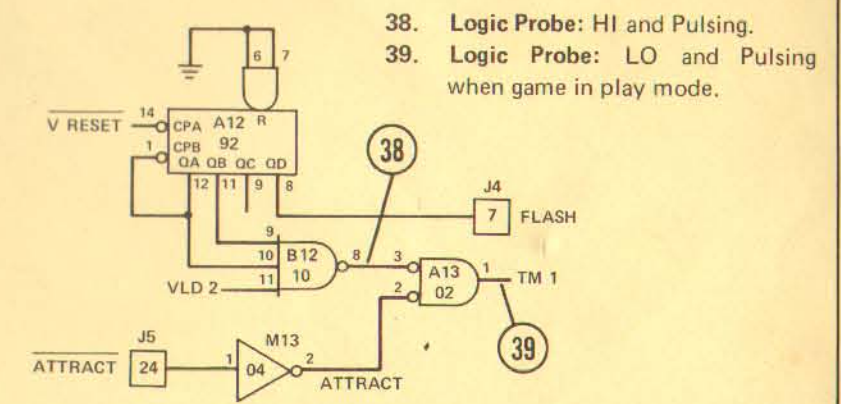

FIGURE 23
FLASH & TM1 SCHEMATIC

All switch inputs are "debounced" before they are allowed to operate any of the logic. For example, the first player's right joystick up switch is debounced by R63, R59, C42 and CR9 before becoming an input to E15-2.

6.2 Tank Rotation & Speed: The various combinations of joystick switches are used to develop two types of signals: (1) Rotation changes the count at H10 (1D0, 1D1, 1D2 & 1D3) and D8 (1D4) so the different tank image aspects are read out of memory. (2) Accelerating or braking changes the GO1 pulse rate which determines how often the motion code is loaded and thereby controls tank velocity.

6.3 Acceleration: To start the tank moving forward, both joysticks must be pushed forward. This closes the switches connected to edge connector pins 12 and 13 and results in a HI from E15-1. This HI is entered at C14-11 along with TM1 and the signal from L13-8 which will be HI unless counter J14 has reached a count of 6. TM1 is a relatively slowly pulsing signal developed in its own circuit (Section 5.6). Since TM1 is inverted by C14, the result (TM1) will increment J14 as long as a count of 6 is not reached.

6.4 Braking: To stop the tank, both joysticks must be pulled back closing the switches connected to edge connector pins 10 and 11. The resulting HI from E15-4 is connected to E14-1 along with TM1 and that result is connected to F14 after which the TM1 pulse resets J14. However, if the game ends, ATTRACT will drop LO and reset counter J14 which will also be reset by BOUNCE (section 7.3) if the tank encounters the outside edge of the playfield perimeter.

Let's assume the tank has been stopped by braking. This clears J14 so its outputs are all LO which produces a HI from K13-8. This HI is inverted by M13 and clears counter H14. To accelerate the tank, both sticks are pushed forward removing the reset condition from H14 which is now free to count. Initially it will count to 15, terminal count (TC) at H14-15 will go HI and the inverted signal is connected back to the parallel entry terminal (PE), loading the number J14 has previously counted to into H14. H14 counts from that number until it again reaches TC and loads a new number. The new result for H14 to reach TC. Since M13-10

- 38. Logic Probe: HI and Pulsing.
- 39. Logic Probe: LO and Pulsing when game in play mode.

is connected to L13-4, L13-6 (GO1) will pulse HI each time H14 reaches TC. The HI pulsing of GO1 increases in frequency as the tank accelerates, causing the motion counters to change the position of the tank more quickly.

However, BOUNCE is also connected to L13 and drops LO whenever an enemy shell hits the tank, producing a HI pulse from GO1. But since GO1 also controls tank direction in the motion circuitry, the GO1 pulse is used to bounce the tank backwards.

6.5 Clockwise Rotation: To turn in the clockwise direction, the left joystick must be pushed forward and the right one pulled back to close switches at edge connector pins 11 and 12. The resulting HI from E15-10 enables TM1 pulses through E14-11 and H11-6 to increment counter H10. Since HIT 2 is also connected to H11, counter H10 will be incremented once if this tank strikes the opponent's tank. This rotates the tank image by one aspect so once a player has "zeroed" in on the other player, he cannot rapidly fire a series of precisely aimed shells. In this sense, the game is quite realistic because actual tanks also must re-aim

after the reaction from each shot and therefore cannot maintain rapid accurate fire.

In any case, when the joysticks are set to turn clockwise, TM1 pulses are allowed through to increment the counter and outputs 1D0, 1D1, 1D2 and 1D3 count up and read new aspects from the ROM. After the first 16 tank aspects are displayed, the counter reaches TCU (Terminal Count UP) which clocks flip-flop D8 through H11 causing 1D4 to change states. Since 1D4 is the MSB (Most Significant Bit) for the tank aspect code, toggling this signal reads out the other 16 aspects by "flipping" the barrel of the tank, but more about this later.

6.6 Counter-Clockwise Rotation: Counter-clockwise rotation results from a similar process except the devices are counted down rather than up. The LOs at edge connector pins 10 and 13 cause E15-13 to rise HI enabling E14 to pass TM1 pulses. Since E14-8 is connected to the count-down input of H10, the counter is decremented. When the counter reaches TCD (Terminal Count Down), flip-flop D8 is again toggled.

SECTION 7

SHELL CONTROL & BOUNCE

7.1 Functions: Shell control occupies most of this circuit (N7, A15, B15, B7 and C9) whereas Bounce is constructed only from B9, A9 and A8. The Shell Control section determines the length of shell travel and time period for explosion and also controls when these events can occur. The Bounce portion merely generates BOUNCE 1 when the first player's tank is hit by the second player's shell.

7.2 Shell Control: If a game is in progress (ATTRACT is HI), the other player's tank is not blowing up (BLO-UP 2 is LO) and if the first player's shell is not already in flight (SRS 1 is LO - see section 15.6), pressing the fire button sets the R-S flip-flop constructed from gates B15. This flip-flop is reset when HMCE (Section 5.4) pulses HI and clocks ATTRACT through A15.

When the flip-flop is set, B15-11 drops LO and triggers the "fire" one-shot C9 which outputs a timed pulse during which the shell travels across the CRT. When the shell has reached the end of its travel (either hit another object or simply exhausted its allotted time), FIRE 1 returns LO, triggering the "explosion" one-shot which generates a 0.3 sec. pulse during which the explosion occurs. Two events can cause the shell to explode before it expends its travel time: (1) If it encounters any part of the playfield display at B7 or (2) If the shell strikes the opponent's tank and HIT 2 occurs. Either of these events resets the "fire" one-shot which triggers the "explosion" one-shot and the explosion occurs.

7.3 White Shell Travel Adjustment: The 50K trimpot connected to the "fire" one-shot may be used to adjust white shell travel to compensate for any differences which might creep in between this circuit and the one for the black tank which would otherwise allow one player to shoot further and have a distinct advantage in firepower. Varying adjustment of the trimpot changes the time constant and length of shell travel is increased or decreased.

- 49. Logic Probe: LO going HI when white tank left joystick is down and right joystick is up.
- 50. Logic Probe: LO going HI when white tank left joystick is up and right joystick is down.
- 51. Logic Probe: LO going HI when both joysticks are down.
- 52. Logic Probe: LO going HI when both joysticks are up.
- 53. Logic Probe: Slow HI pulses when tank rotates counter-clockwise.
- 54. Logic Probe: Slow HI pulses when tank rotates clockwise or pulses LO once if the tank is hit by black shell.
- 55. Logic Probe: Pulses LO when counter has advanced beyond a count of 15.
- 56. Logic Probe: Pulses LO when counter is decremented beyond a count of 0.
- 57. Logic Probe: Pulses high if TP55 or

TP56 pulses LO.

- 58. Logic Probe: Reset HI when game starts. Thereafter, changes states each time TP57 pulses LO.
- 59. Logic Probe: LO pulsing HI when tanks collide or if the white tank encounters a wall. Rises HI during attract mode. Pulses slowly when both joysticks are down.
- 60. Logic Probe: HI going LO when counter J14 reaches count of 12.
- 61. Logic Probe: HI until both joysticks are up and then pulses slowly until counter J14 reaches count of 6.
- 62. Logic Probe: HI going LO when counter J14 reaches count of 0.
- 63. Logic Probe: LO pulsing HI at a rate proportional to tank velocity.
- 64. Logic Probe: Same as TP63, but also pulses HI if tank encounters other tank or wall.

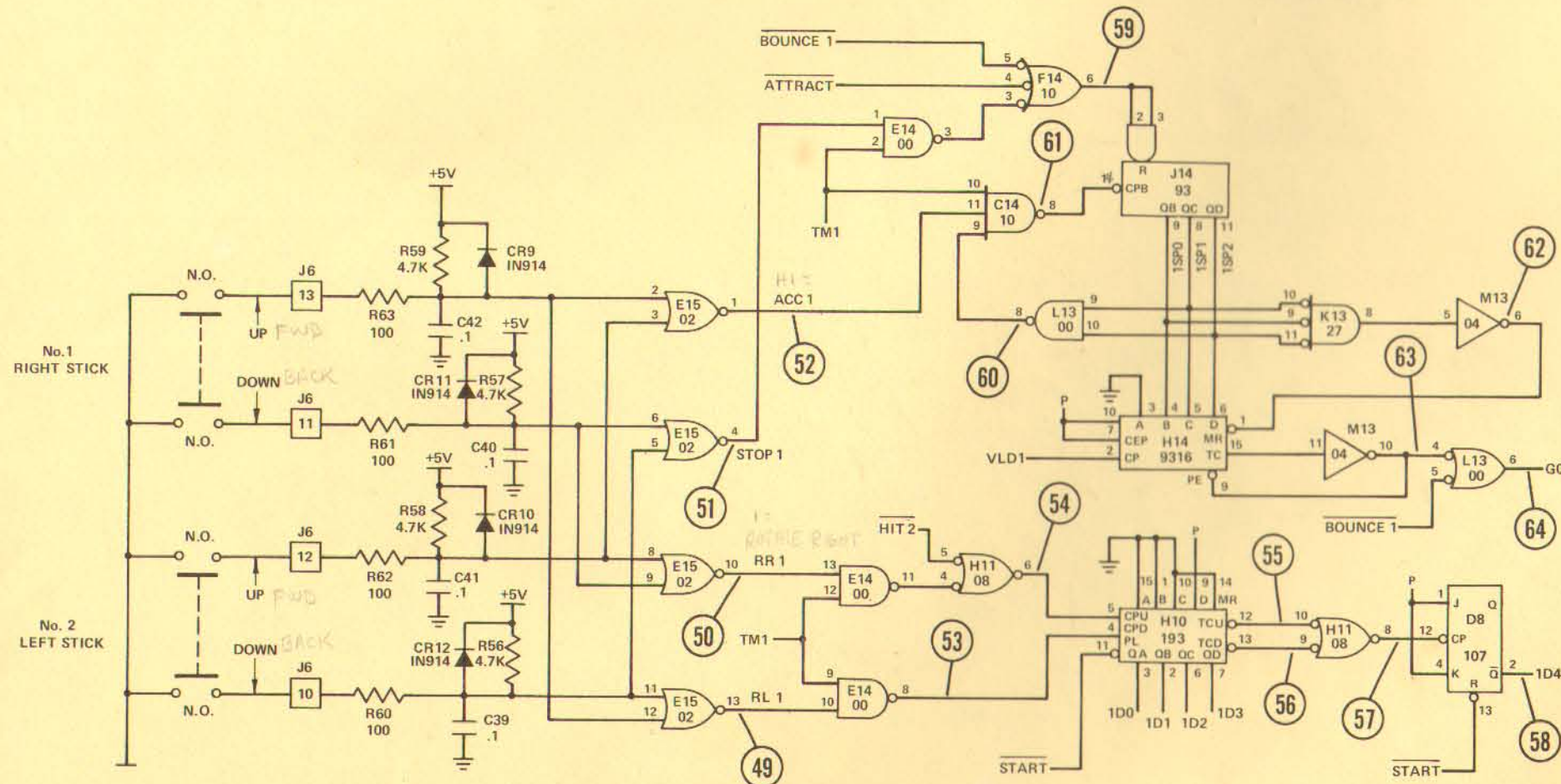

FIGURE 24
TANK1 CONTROL SCHEMATIC

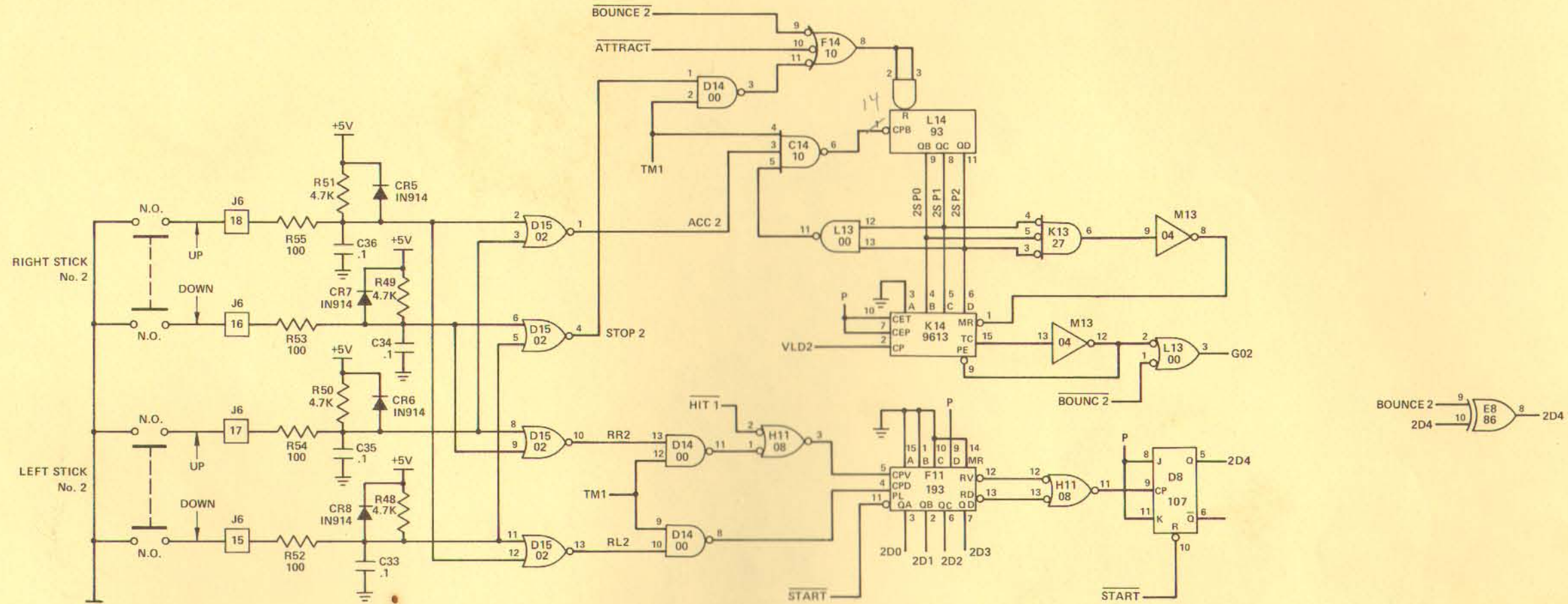

FIGURE 25
TANK 2 CONTROL SCHEMATIC

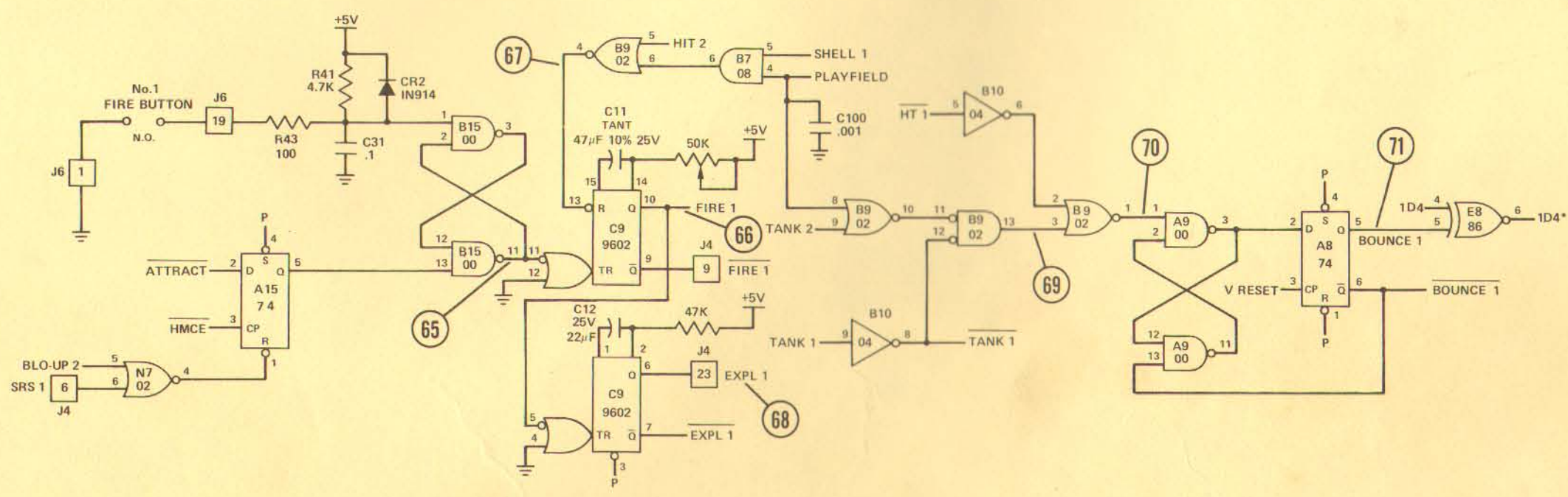

FIGURE 26
SHELL 1 CONTROL SCHEMATIC

- 65. Logic Probe: HI going LO when shot is fired. Remains LO until shell explodes.
- 66. Logic Probe: When shot is fired, LO going HI 0.75 sec. later unless reset by TP67.
- 67. Logic Probe: HI pulsing LO if shell encounters playfield or if shell encounters opponent's tank.
- 68. Logic Probe: LO going HI for \cong 0.32 sec. when TP66 returns LO.
- 69. Logic Probe: Pulses HI when white tank encounters black tank or playfield.
- 70. Logic Probe: Pulses LO if TP69 pulses HI or if hit by black shell.
- 71. Logic Probe: Pulses HI if TP70 pulses LO.

7.4 Bounce: A BOUNCE signal can be generated by any one of three events: (1) If TANK 1 encounters TANK 2 or PLAYFIELD at either half of B9. (2) If TANK 1 is hit by SHELL 2. (3) If TANK 1 encounters a mine (HT 1). When one of these events occurs, B9-1 drops LO setting the R-S flip-flop constructed from gates A9 and A9-3 pulses HI. This HI is clocked through flip-flop A8 by V RESET and the LO at the \bar{Q} output resets the R-S flip-flop. The resulting LO at A9-3 is clocked through A8, again by V RESET. This process generates BOUNCE which is exclusively ORed with 1D4 to develop 1D4*, an instruction for the memory to back up the tank.

SECTION 8

SCORE

8.1 Score Generation: You have probably noticed the exceptionally fine shapes of the score numerals displayed in this game. The mere fact that these numerals are of such high quality should immediately cue you

that this is not an ordinary seven-segment display. The way these numerals are generated is simply by storing the exact shapes in the ROM and reading them out when needed. Since the architecture of the game required by a ROM anyway, it was simpler and more advantageous just to store the numerals rather than to generate them using the hard-wired logic of the gated or multiplexed seven-segment display which not only uses considerably greater PCB area, but also cannot realistically develop such pleasing shapes. However, when using a ROM to store the numerals, the designer is limited only by his creativity and aesthetic capabilities for he plots the exact shapes on a piece of graph paper and then has this information programmed into the ROM. The ROM stores the image data necessary to generate the complete set (0 through 63) of numerals. It does not store a set of 0 through 9 where the same data is used to generate the numeral in both the ones and tens places.

8.2 Score Increment & Storage: Score counting and storage is still accomplished the normal way by the following circuit which detects score-producing events and counts them. The score counts for both players are later multiplexed together and used to read out the proper numerals from the ROM which are used in common for both players.

Obviously, since there are two players where each player has a separate score, there must also be two separate score increment and storage circuits. Upon cursory examination, these circuits may not appear identical, but we will see how the electrical configuration of both score circuits is absolutely identical in every respect.

8.3 Score Events: A player's score may be incremented by one of two events. If one player fires on and hits the other player's tank, the player who fired the shot is awarded one point. Or, if one player drives his tank into one of the mines, the opposing player is awarded the point.

For example, if the shell fired by the first player (SHELL 1) encounters the second player's tank (TANK 2), K8-6 drops LO and presets flip-flop J8. This produces a HI at HIT 2 which elicits a LO from J7-1. On the rising edge of the next V RESET pulse, a LO is clocked through J8-5 producing a HI from J7-1 which advances the count at C10 by one. The same effect also results if the second player's tank has encountered a mine at which time MTK 2 pulses HI and again elicits a LO from J7-1. In either case, C10 is incremented each time one of these events occurs.

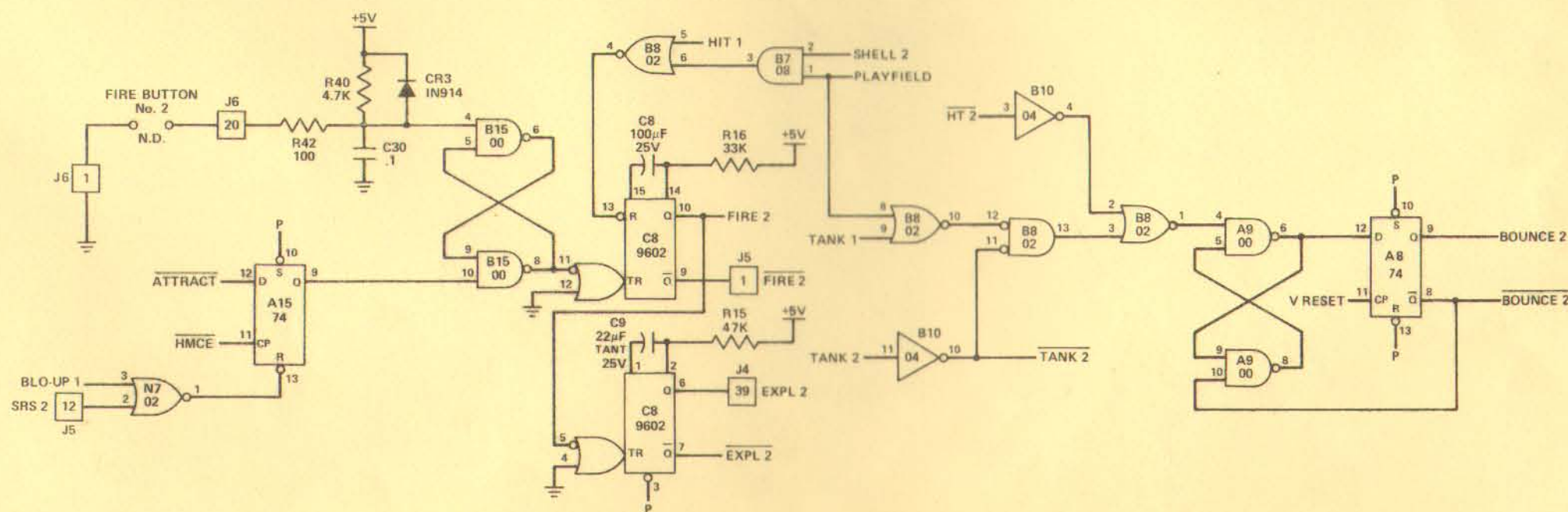

FIGURE 27
SHELL 2 CONTROL SCHEMATIC

8.4 Operation: The outputs of counter C20 provide the first four bits of the binary number entered at the multiplexers for the ROM and these outputs are designated SCR1A, SCR1B, SCR1C and SCR1D (score bits Q_A through Q_D for player 1). However, there are actually six bits used for each player's score so that a full count of 63 may be reached by an exceptional player or, more likely, by a technician with a pulser. This is done by taking advantage of an idiosyncrasy of 7493 counters. All 7493s are manufactured in such a way that the Q output of the first internal

flip-flop is not connected internally to the clock of the second flip-flop and must be connected externally to provide a four-bit counter. This way, the designer has the choice of using a chip which contains a flip-flop and a three-bit counter or a full four-bit counter. Notice that pin 1 of C10 is connected to pin 12 of the same counter, but that pins 1 of D11 and E11 are not connected to pins 12. In this way, the first two bits of the second player's counters are used to provide the fifth and sixth bits (SCR1E and SCR1F) for the first player.

- 72. **Logic Probe:** LO pulsing HI when white tank hit by black shell.
- 73. **Logic Probe:** HI pulsing LO if TP72 pulses LO or if white tank encounters a mine. NOTE: TP72 and TP73 advance black score.

- 74. **Logic Probe:** Pulses HI at start-game.
- 75. **Logic Probe:** Six-bit binary number for white tank score. Example: 37 = 1 0 1 0 0 1 at SCR1A, SCR1B, SCR1C, SCR1D, SCR1E and SCR1F.

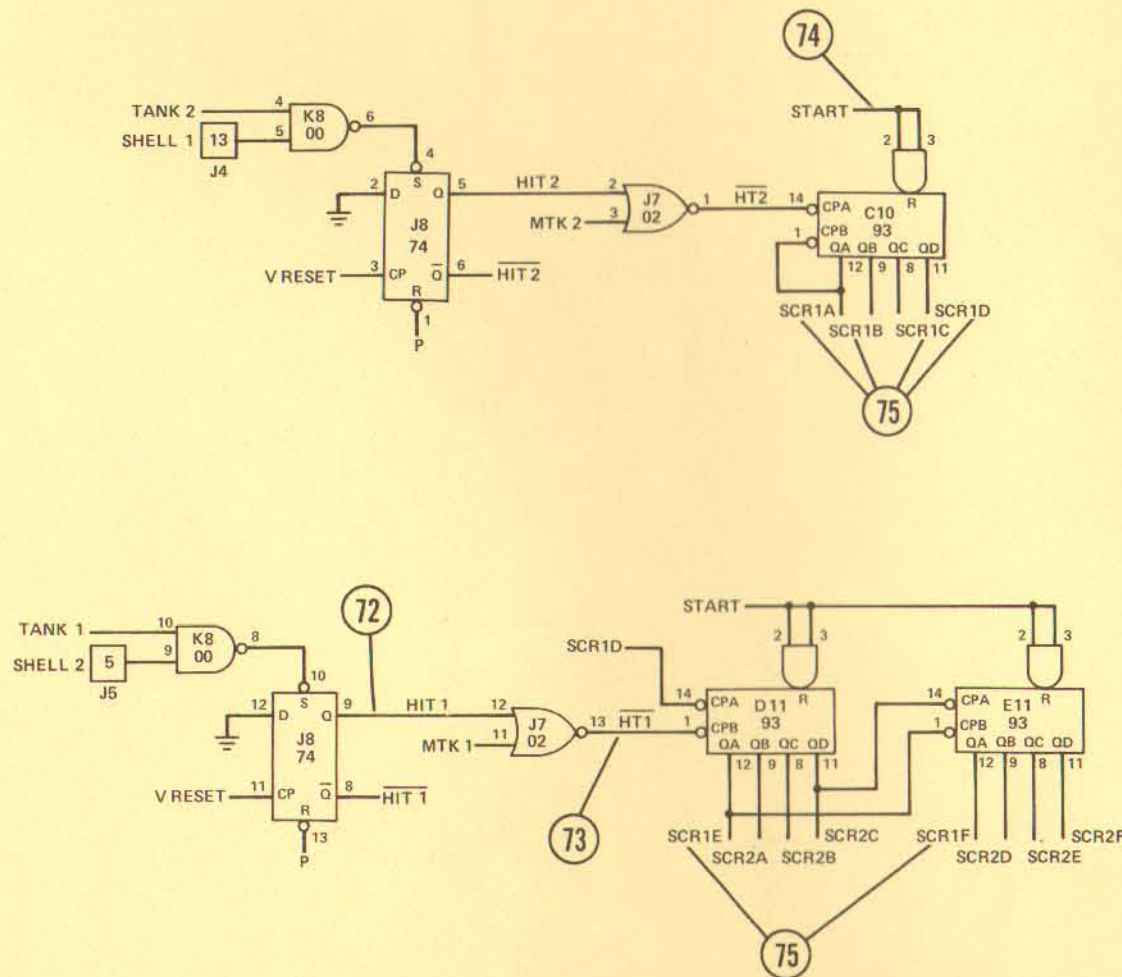

FIGURE 28
SCORE SCHEMATIC

SECTION 9
THE MEMORY

9.1 Functions: The ROM in Figure 33 stores the binary information necessary to generate the score numerals, the playfield objects and the different aspects of the tanks. In addition, the ROM also stores motion codes used to generate realistic motion for the various tank aspects. The ROM used here is a 2048-word by eight-bit device which is organized internally into four 512-word blocks where each stores a different group of information (Figure 29). The different blocks are accessed by the code at the A^9 and A^{10} address inputs. For example, when the "block address code" is 0 1, the score data is accessed.

00 POSITION INFORMATION
01 SCORE NUMERAL DATA
10 TANK ASPECT DATA
11 PLAYFIELD INFORMATION

FIGURE 29
ROM STORAGE BLOCKS

9.2 Preliminary Multiplexing: The functions of multiplexers F10, F8, H8, D10 and E10 are simply to multiplex both player's inputs together. The signal 64H is used to select F10, F8 and H8 because the information is read out of the ROM by H INFO which is a pulse lasting for 128H. Therefore, the select 64H allows one player's information to address the ROM during the first half of H INFO and the other player's data during the second half of H INFO. Multiplexers D10 and E10 are selected by 452H so the score data for the first player appears on the right and the score data for the second player appears to the left of 452H.

9.3 Address Multiplexing: The information multiplexed in Section 9.2 is further multiplexed by D9, E9, J9, H9 and F9 to develop the actual ROM address and this process is illustrated by Figures 30 and 31.

INFORMATION	MUX SELECTS	ROM ADDRESS INPUTS										
		A ⁰	A ¹	A ²	A ³	A ⁴	A ⁵	A ⁶	A ⁷	A ⁸	A ⁹	A ¹⁰
POSITION	0 0	D0	D1	D2	D3	D4*	0	64V	128V	256V	1 or 0	0
SCORE	1 0	4V	8V	16V	SCRA	SCRE	SCRC	SCRD	SCRE	SCRF	0	1
TANK IMAGES	0 1	02	03	04	D4	32H	D0	D1	D2	D3	1	1
PLAYFIELD	1 1	64H	128H	256H	452H	16V	32V	64V	128V	256V	1 or 0	0

FIGURE 30
ROM ADDRESS TABLE

Notice that the A selects (pins 14) of the multiplexers in Figure 33 are controlled by H INFO and that the B selects (pins 2) are controlled by V INFO. The conditions of these signals enable the multiplexers according to the areas illustrated in Figure 31 and, when enabled, the multiplexers pass the information necessary to address the desired data from the ROM.

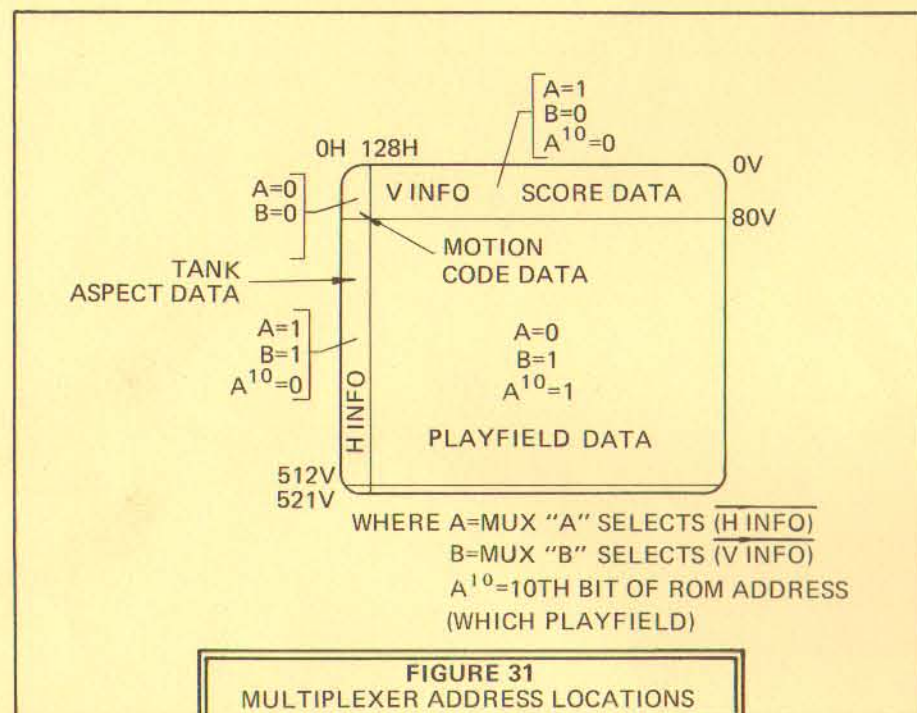

9.4 Score Data: For example, during the score window the A selects = 1 and the B selects = 0 at each of the multiplexers. Since these are all dual four-to-one multiplexers, a binary select code of 1 0 selects input pins 5 and 11 and the signals at those pins appears at output pins 7 and 9. Therefore, whenever the electron beam is in the score window area of Figure 31, the score signals at the multiplexers are enabled through to address the proper numeral from the ROM. The first three address bits (4V, 8V and 18V) tell the ROM what line of the score window the electron beam is scanning and the next six bits chose the actual numeral. The score signals at address bits A³ through A⁸ form a "higher order" address selecting the character which in this case is a numeral from 0 to 63. Then, within that address, the first three address bits address the ROM for every pair of lines in the score window and the information needed to generate the chosen character is read out.

The last two bits of the address (A⁹ and A¹⁰) are the highest order address which selects one of the four internal blocks of 512 words stored in the ROM. It is an interesting fact that there are 64 different scores stored in the ROM and since each score requires 64 bits of memory, a total of 4096 bits is required to store all the numerals from 0 to 63. And this exactly fills up one of the four blocks of ROM data for each block contains 512 words of eight bits each or 4096 bits in all.

The width and positioning of the score is controlled at shift register N10 (Section 11.2) in the Video Summation Network. Since N10 is clocked

by 4H, each bit of the eight-bit score numeral word is read out for eight clock pulses causing the final numeral window to be 64 clock pulses wide. The numbers are positioned in the desired area by PFLD (Section 10.2) at N10-1 which appears as a short vertical streak to the left of each player's score. Since PFLD controls the shift/load input of the register, the parallel ROM data is loaded when PFLD drops LO and is shifted out serially on the next rising edge of 4H after PFLD returns HI. Hence, the score numerals appear to the right of PFLD on the CRT.

9.5 Position Data: The ROM is addressed for this information when the selects for the multiplexers are A=0 and B=0 or, in other words, when the electron beam is in the small rectangle in the upper left corner of Figure 31. During this time, the first four bits of the address read out the contents of data block 00 in the ROM which contains binary motion codes. Since the first four address bits (D0, D1, D2 and D3) are both player's multiplexed tank rotation counts (Sections 6.5 and 6.6), the ROM will read out a different binary motion code for each of the 32 tank aspects. In other words, if the tank is turned while moving, its motion must follow a realistic curve. The function of the ROM information at this point is to supply the data necessary for moving the tank image in the curve.

9.6 Playfield Data: The playfield data is retrieved when the electron beam is scanning the large rectangle in Figure 31 where both A and B are HI. Two different playfields are stored in the ROM and are selected by moving the jumper wire to D9-6. If D9-6 is grounded LO, one block of ROM data (00) will be accessed for address bits A⁹ and A¹⁰ will both be LO. The other playfield can be retrieved by tying D6-9 HI which will access the 01 block of ROM data. Due to the construction of the address multiplex system, adjusting D6-9 for the playfields also affects the address for the position information, hence the position information must be duplicated in both data blocks.

Once the desired data block is chosen, the lesser order address at inputs A⁰ through A⁸ retrieves the specific data needed to generate the playfield obstruction shapes as well as the mine locations. Horizontal inputs 64H, 128H, 256H and 452H address the ROM for the horizontal data

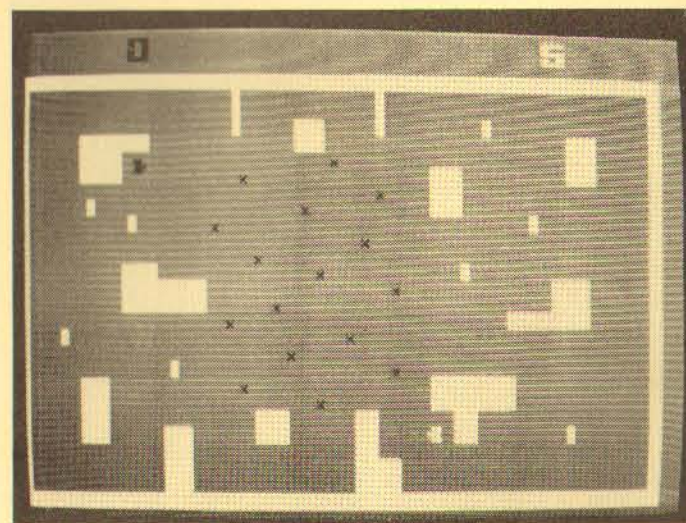

Alternate Playfield: This playfield is produced by tying D9-6 LO.

while 16V, 32V, 64V, 128V and 256V retrieve the vertical information. Since 64H is the fastest signal, the address changes every 64 clock pulses and an eight-bit word is read out. This eight-bit word can generate a 64H wide image because the data is clocked from N10 and 4H in the Video Summation Network (Section 11.2). Therefore, eight bits are clocked out for eight clock pulses each and if all eight bits are programmed HI, the resulting part of the playfield obstruction will be 64 clock pulses wide. Consequently, these obstruction shapes may be anywhere from 8 to 64 clock pulses wide for an 8 clock pulse wide shape will result if only one of the eight bits are programmed HI. Since 16V is the lowest order vertical address, any bit programmed HI will be scanned white for a total of 8 lines down the CRT, hence the minimum height of the obstructions is 16V.

9.7 Tank Aspect Data: The ROM is addressed for the tank aspect data when the thin vertical strip on the left of Figure 31 is being scanned and during this time the data file containing this information is accessed by HI states at both the A⁹ and A¹⁰ address inputs.

The first three address bits (A⁰, A¹ and A²) are controlled by both player's multiplexed motion counter outputs (02, 03 and 04). These signals produce a count which always begins at 0 0 0 and ends at 1 1 1 and this is illustrated in Figure 32. Keep in mind that this address is a motion count which is retarded or advanced with respect to sync if the tank is moving. In any case, notice that the address in Figure 32 changes only once every two lines since the Q_A output is not used for the LSB. Therefore, each new code reads out the same information for two lines. And as the electron beam is scanning those two lines, the ROM reads out an eight-bit word containing the tank image data specified by the image address inputs A⁵ through A⁸. However, these four bits cannot supply a large enough count to generate 32 different images. The other 16 images are produced at A³ where the state of D4 flips the tank barrel to the other end of the tank so that the first 16 images can be reused, so to speak.

At this point, you may be wondering how an eight-bit word from the ROM is used to generate a 16-bit wide tank image. This function is controlled by 32H at A4. Shift registers A3 and B3 in Section 15.10 are loaded by LDH1A and LDH1B (Section 13.2) and there is a time period of 32H between the rising edges of these two signals. Therefore, when 32H at ROM address input A⁴ is HI, one half of the tank data is loaded into A3 and when this address input is LO, the other eight bits of the data are loaded into B3. Then, when the shift registers are enabled by the tank window, all 16 bits are shifted out serially.

SECTION 10

PLAYFIELD & SCORE LOAD

10.1 Functions: This small circuit develops the signal PFLD which loads the playfield and score information into shift register N10 (Section 11.2) so the information can be properly displayed on the CRT.

10.2 Score Load: First V INFO (Section 4.12 and occurring between 512V and 80V) is gated with 32V and the differentiated signal 256H at

H13. Signal 256H is differentiated so the information is loaded only for an extremely short period of time. If examined with the video probe, V INFO is a horizontal band which actually extends from the extreme bottom edge of the CRT to the top outside edge of the playfield perimeter. Signal 32V is simply a set of thin vertical columns and the differentiated signal 256H appears as two very thin vertical lines occurring in the normal places 256H makes its transitions. Gating all this together produces a very short vertical line to the left of each player's score information and this signal is used to load the score information prior to display.

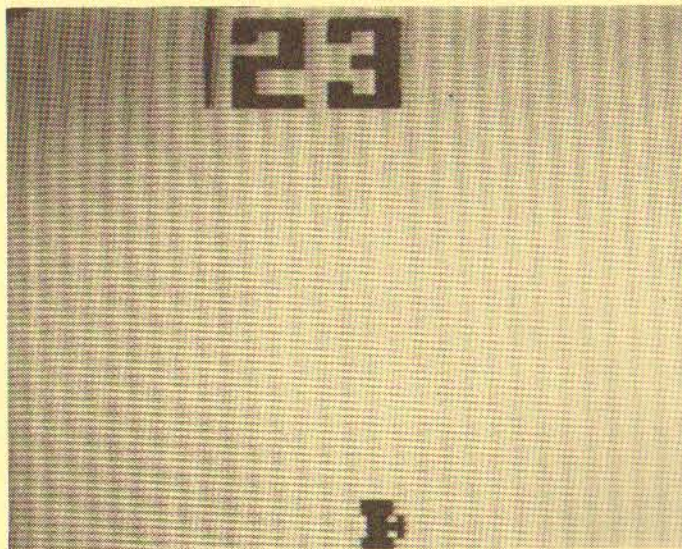

SCORE LOAD: SCORE LOAD appears as the black vertical line to the left of the number and this detail has been produced by subtracting the rest of the playfield display.

10.3 Playfield Load: In this case, V INFO is used to select that area of the CRT from 80V to 512V or, in other words, the area underneath the score (from the top of the playfield perimeter down to the bottom of the CRT). This signal is gated with differentiated 32V which appears as a series of thin white vertical lines. The result at A10-3 is simply these lines inverted black and appearing only in that area from the top of the playfield perimeter down to the bottom of the CRT.

10.4 PFLD: PLAYFIELD LOAD and SCORE LOAD are gated together at A10-5 and A10-4 and this result is gated with H INFO (Section 4.8) at A10-9 so the information used for generating the tanks is prevented from being loaded for the playfield and score displays.

SECTION 11

VIDEO SUMMATION

11.1 Functions: Normally, a video summation network simply adds all the video outputs across the appropriate values of resistors to establish relative display brightness and then couples the resulting information to

the TV monitor. The circuit in Figure 35 however also performs a certain amount of gating and control functions as well as serializing the playfield and score video for final display.

11.2 Operation: Since the playfield information from the ROM is generated in parallel (simultaneously occurring) form, it must be converted to a serial (sequentially occurring) format so that the data can be displayed a bit at a time as the electron beam scans the CRT. The parallel playfield data is loaded into shift register N10 when the playfield load signal PFLD pulses LO and clocked out of N10 by 4H which establishes

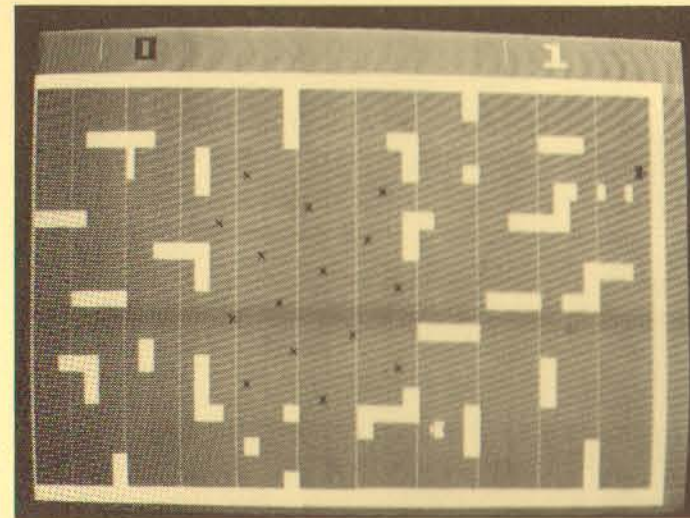

PFLD: This signal generates the two short vertical white lines to the left of the score numerals and the tall vertical lines inside the playfield which are used to load the score and playfield information into the shift registers prior to display.

the minimum width of the playfield objects. The resulting signal from N10-9 contains the serialized score, playfield and mine information. This information enters K13 along with 512V and MINEFIELD where 512V is included to prevent sync disruption. The inclusion of MINEFIELD is necessary to remove the mine location windows which would otherwise cover the mines. The resulting signal is known as PLAYFIELD and it is gated at A11 with the output from C14-12 which causes the score numbers to flash when end-game is near. The output of C14-12 is generated by NANDing GNE, V INFO and FLASH. Therefore, anything occurring within the horizontal window established by V INFO (the score numerals) will be rapidly turned on and off by FLASH when GNE (Game Near End, Section 3.8) goes HI. This result is known as PLAYFIELD VIDEO.

PLAYFIELD VIDEO is entered at both F14-13 and J11-9. Combining this signal with V INFO at F14 selects the score information and the inclusion of 452H at this same gate separates the right and left score displays. Since 452H is LO on the left, the left score display is read out black. This result is added to TANK 1 across R5 and R34 and taken directly to the video coupling capacitor.

SHELL 1 or BLAST 1 is inverted by L7 and ORed with PLAYFIELD

VIDEO at H8 before being sent to the monitor. Since H8 inverts the displays, SHELL 1, BLAST 1 and PLAYFIELD VIDEO appear white on the CRT.

COMP SYNC is added across diode CR1 which is necessary to isolate the time when COMP SYNC is HI from the rest of the information so it cannot pull everything else up during this time.

TANK 2 is NORed with MINE at D7 and this signal is ORed with that from N7-10 which consists of SHELL 2 ORed with BLAST 2. This is done in this way so the resulting images are all read out black.

C29 is the video coupling capacitor and the video probe is attached to the negative (-) side of this cap.

SECTION 12

MINE CIRCUITRY

12.1 Functions. The following three sub-circuits develop the mine shapes, enter them into locations supplied by the ROM and subtract the exploded ones.

12.2 Mine Matrix: The small circuit in Figure 37 generates the actual mine shapes, 16 of which are later selected to appear in locations determined by information stored within the ROM. The matrix generation

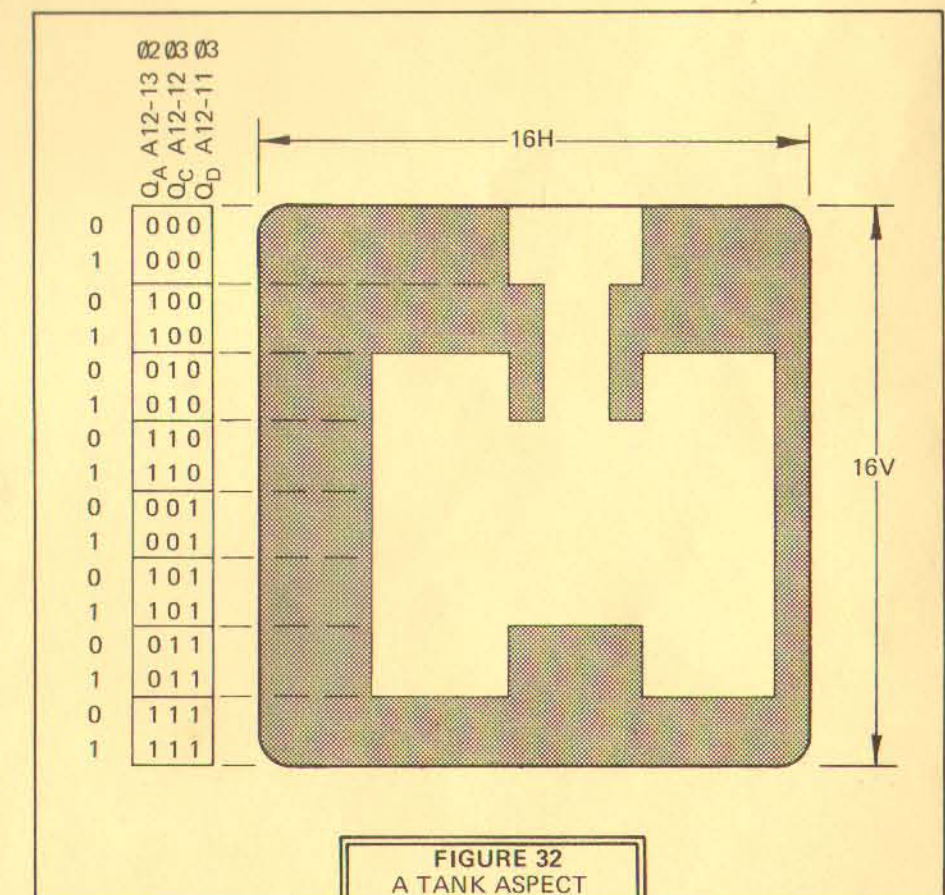

FIGURE 32
A TANK ASPECT

76. **Logic Probe:** HI, LO and Pulsing.
Video Probe: Series of alternating light and dark vertical stripes with a wider dark stripe in center of CRT.
77. **Logic Probe:** HI, LO and Pulsing.

- Video Probe:** CRT divided in half vertically where left is dark and right is light.
78. **Logic Probe:** HI, LO and Pulsing.
Video Probe: See Figure 31.
79. **Logic Probe:** HI, LO and Pulsing.
Video Probe: Alternating narrow light and dark vertical columns.

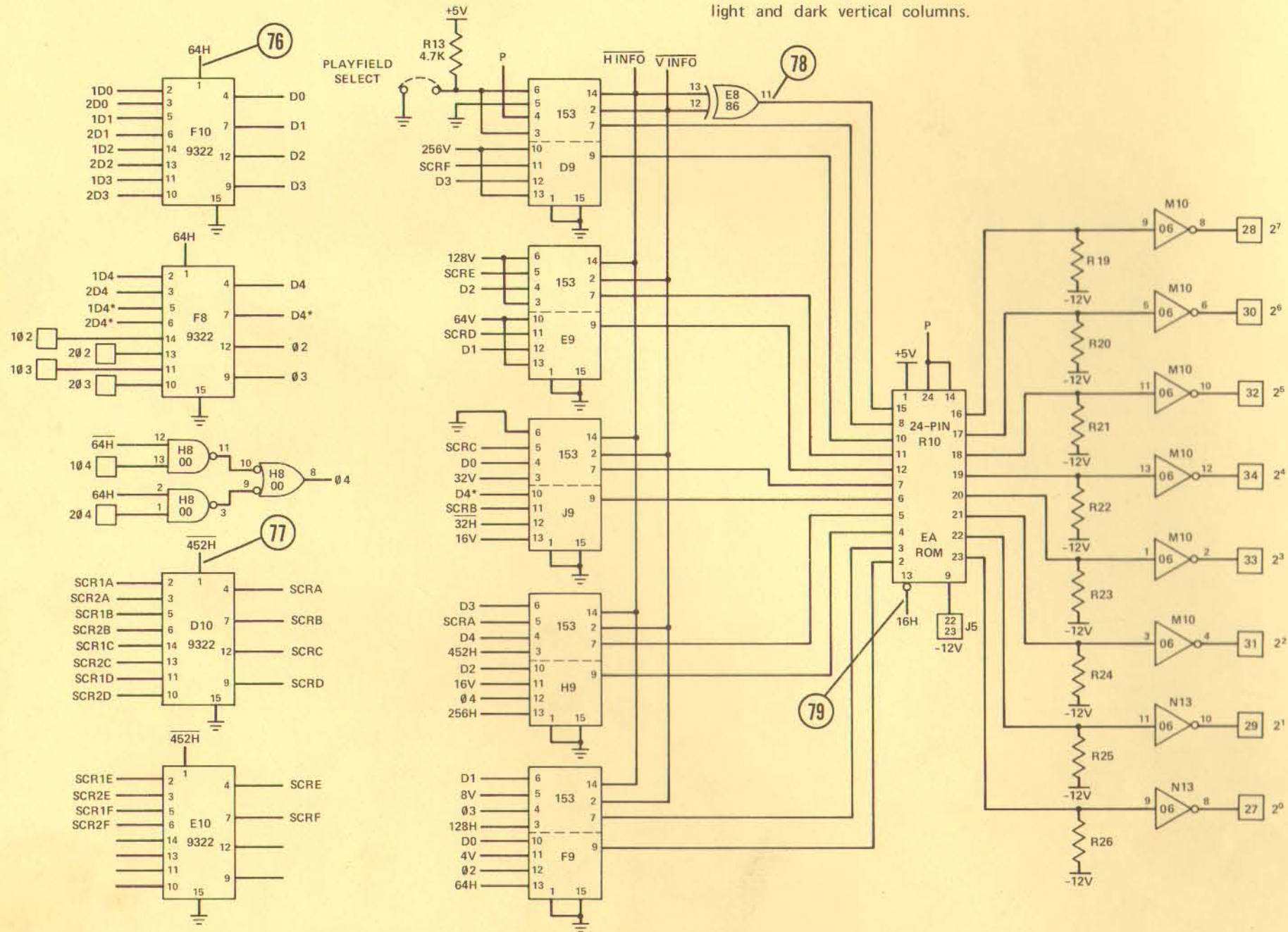

FIGURE 33
THE MEMORY SCHEMATIC

80. **Logic Probe:** LO and Pulsing.
Video Probe: Two light vertical lines near score.
81. **Logic Probe:** HI and Pulsing.
Video Probe: Two dark vertical lines near score.
82. **Logic Probe:** LO and Pulsing.
Video Probe: Series of light thin vertical lines.
83. **Logic Probe:** HI and Pulsing.
Video Probe: Dark, thin vertical lines within playfield.
84. **Logic Probe:** LO and Pulsing.
Video Probe: Light thin vertical lines within playfield and a single light thin vertical line next to each score.

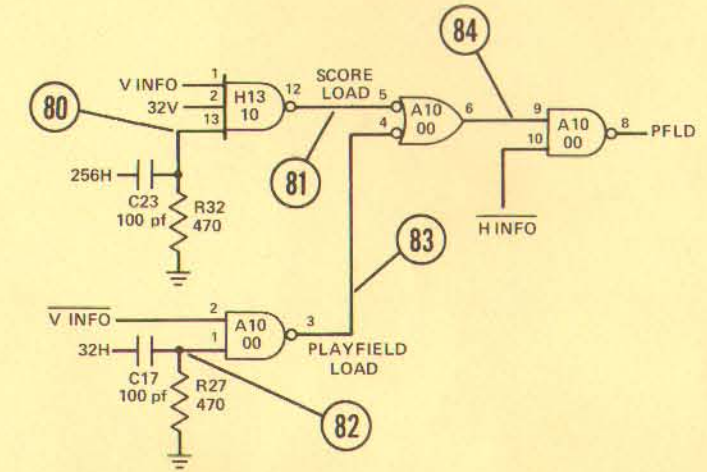

FIGURE 34
PLAYFIELD & SCORE LOAD SCHEMATIC

process is most easily understood if the developmental process is examined with a video probe in conjunction with the following analysis. Nevertheless, we have included several illustrations of this process for convenience.

The basic checkerboard pattern is developed by gates F13. First 4V and 2V are exclusively ORed with each other to generate a pattern of horizontal bars which alternate light and dark (Figure 36a). This result is then exclusively ORed with a similar but vertical pattern (Figure 36b) from F13-11 to develop the checkerboard pattern at F13-6, part of which is shown in Figure 36c. When this pattern is NANDed with the pattern of squares produced by ANDing 8H with 8V at A10, part of the information in Figure 36c is selected by the dark square in Figure 36d to generate the actual mine shape in Figure 36e.

If you examine D7-1 with the video probe, you will see the entire CRT covered with these mine shapes. The 16 desired mines are selected later by location information stored in the ROM. This information contains the exact vertical and horizontal coordinates of each mine location and generates location windows in which the mines are positioned (Section 12.4).

12.3 Minefield: This sub-circuit supplies a rectangular window in the center of the CRT into which the mines are later displayed. The output

of H13-6 drops LO at 160V and sets the R-S flip-flop composed of gates B14 which is reset by the signal from H13-8 when it drops LO at 416V. The output of H13-8 can only be seen if the horizontal hold of the monitor is adjusted so the extreme right edge of the playfield is moved slightly leftward. This signal then appears as two small black squares in the lower right corner of the CRT. The output of the R-S flip-flop is known as MEV and it is HI from 160V to 416V. MEH is a similar signal except it is horizontal in nature. It is HI from 384H to 596H. Both MEV and MEH are gated together at A13 and the result at A13-4 is a large white rectangle in the center of the CRT.

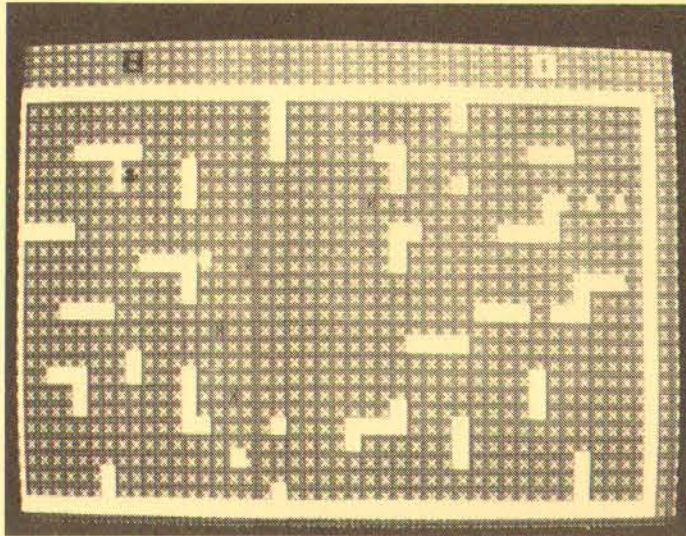

MINE MATRIX: This pattern of mine shapes is known as the MINE MATRIX. Sixteen of the mines are later selected to appear in the proper places by FIELD.

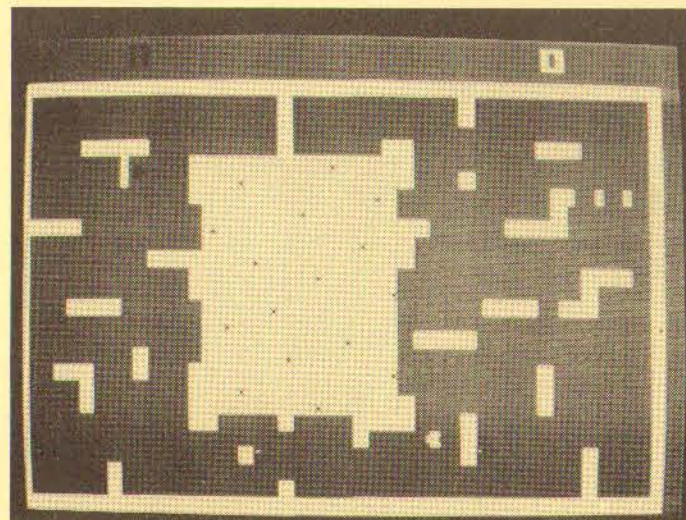

MINEFIELD: This signal generates a rectangular window for the entire group of mines.

12.4 Mine Control: Now that the mine shapes have been generated, there must also be a way to remove those mines which are hit by a tank and explode. The following circuit keeps track of the "live" and exploded mines as well as providing the signal which is used to give a point to the player who did not encounter the mine. The circuit operates by recirculating information through a shift register, a scheme used in several other games for similar features. Basically, the mine information appears from the Q output of the shift register (pin 14) and goes through J7 unless a collision has occurred and the signal from K7-8 shuts off the expended mine image.

F7 is a 16-bit shift register where each bit corresponds to one of the 16 different mines. When START pulses LO at the beginning of the game, zeroes are loaded into the shift register which then clears H7. If the first player drives his tank into a mine (TANK 1 encounter MINE at K7), the LO from K7-11 presets the upper half of H7 and MTK1 drops LO. Since both MTK1 and MTK2 are connected at K7-9 and K7-10, a LO MTK1 produces a HI from K7-8 which disables the mine information from the

shift register at J7 and the resulting LO is clocked into the serial input of F7, thereby shutting off that mine image. On the next 8V pulse and during the vertical mine window, the output of A11-8 clocks a HI from H7-6 (MTK1) and the shift register is then allowed to continue to recirculate mine information.

The selected mine signals from J7-10 are directed to appear in the correct areas of the CRT by the signals at gate E7. MINE MATRIX is the signal developed in Section 12.2 which contains a pattern of mines covering the entire CRT. Sixteen of the mines are selected and correctly positioned by FIELD, the mine location signal from the ROM. MINE-FIELD is the large rectangular window generated in the previous section and its inclusion here, while not immediately obvious, is quite necessary since the playfield obstruction information coming from the memory is HI. Were MINEFIELD not included at this point, the playfield obstructions would be filled in with mine shapes. For the same reason, no obstructions are placed within the window defined by MINEFIELD.

- 85. **Logic Probe:** HI, LO and Pulsing.
Video Probe: Dark playfield, score and mine windows.
- 86. **Logic Probe:** HI, LO and Pulsing.
Video Probe: Lightens playfield and score.
- 87. **Logic Probe:** HI until game nears end, then alternates between HI and HI, LO and Pulsing.
- 88. **Logic Probe:** HI, LO and Pulsing.
Video Probe: same as TP86 except score is turned on and off as game nears end.
- 89. **Video Probe:** Darkens score numeral(s) on left.
- 90. **Video Probe:** Lightens BLAST 1, SHELL 1 and playfield.
- 91. **Video Probe:** Darkens mines and Tank 2.
- 92. **Video Probe:** Darkens BLAST 2 and SHELL 2.
- 93. **Video Probe:** Darkens mines, TANK 1, SHELL 2 and BLAST 2.

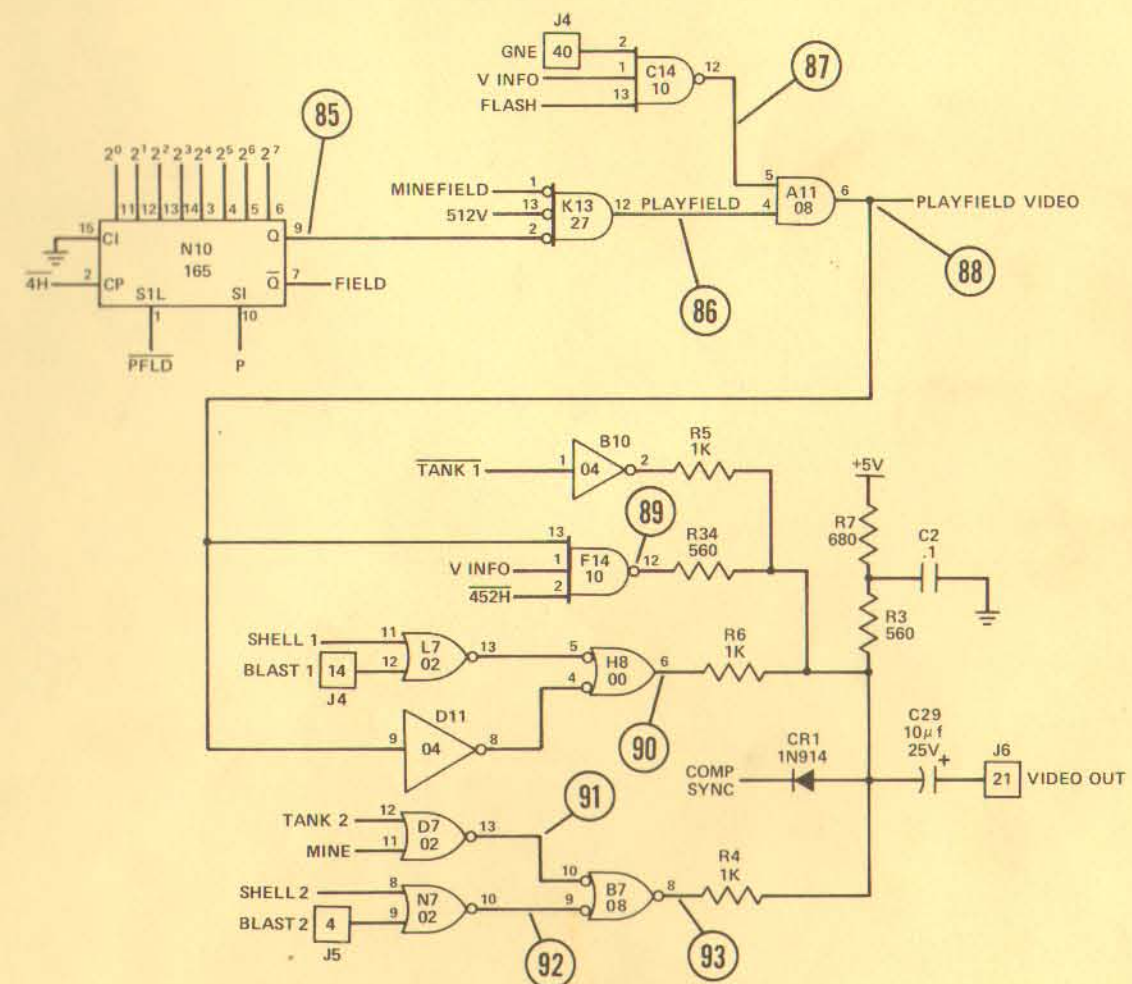

FIGURE 35
VIDEO SUMMING SCHEMATIC

SECTION 13

VERTICAL & HORIZONTAL LOAD

13.1 Functions. This circuit generates both vertical and horizontal load signals where the horizontal signals LDH1A, LDH1B, LDH2A and LDH2B are used to load the tank image information into the shift registers for display and the vertical signals VLD1 and VLD2 enter new position information into the motion counter chains.

13.2 Horizontal Load: Chip L11 is a dual one-of-four decoder selected by 32H and 64H and enabled by the signal from D14-6. This signal is produced by NANDing 16H with H INFO to form four 16H wide LO-going pulses. During these LO periods, the combination of 32H and 64H selects which output will reflect the LO, however note that only half of the available outputs are utilized. This produces a set of staggered LO-going 16H wide pulses which are separated by 16H so the information can be read out of the ROM and loaded into the shift registers at 16H intervals.

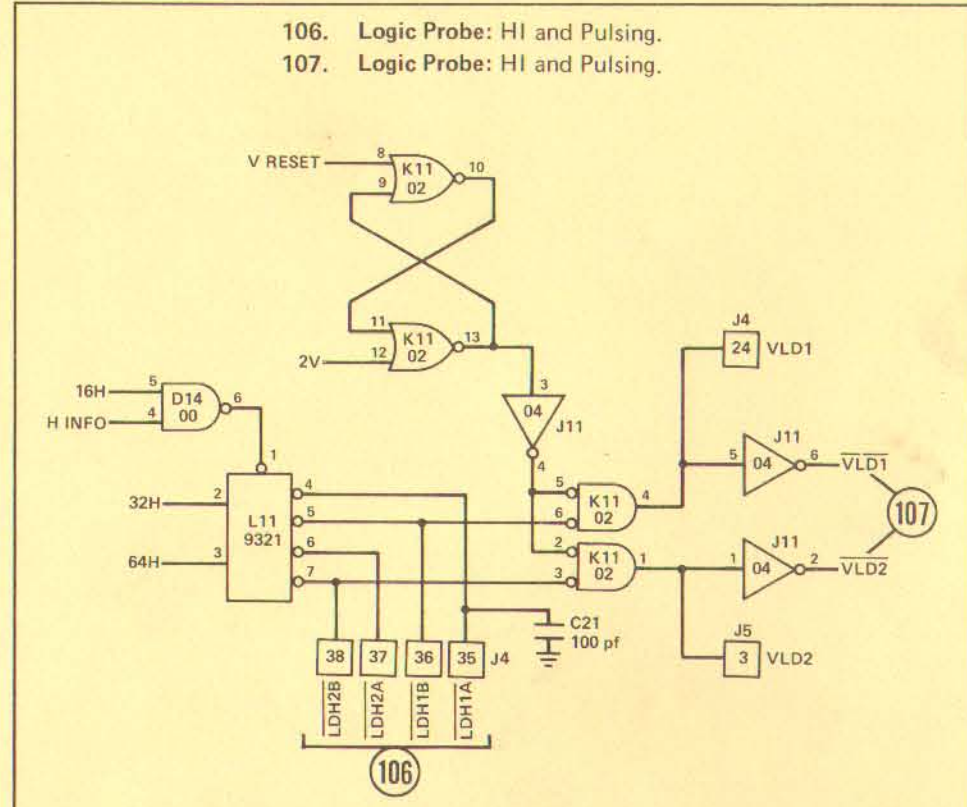

FIGURE 40
HORIZONTAL & VERTICAL LOAD SCHEMATIC

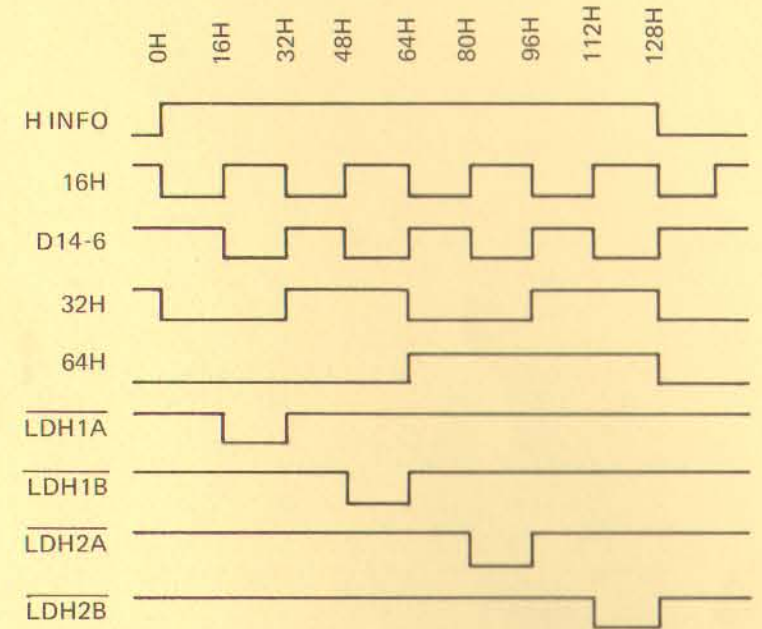

FIGURE 41
DEVELOPMENT OF HORIZONTAL & VERTICAL LOAD

108. Logic Probe: LO pulsing HI at a rate proportional to tank velocity.

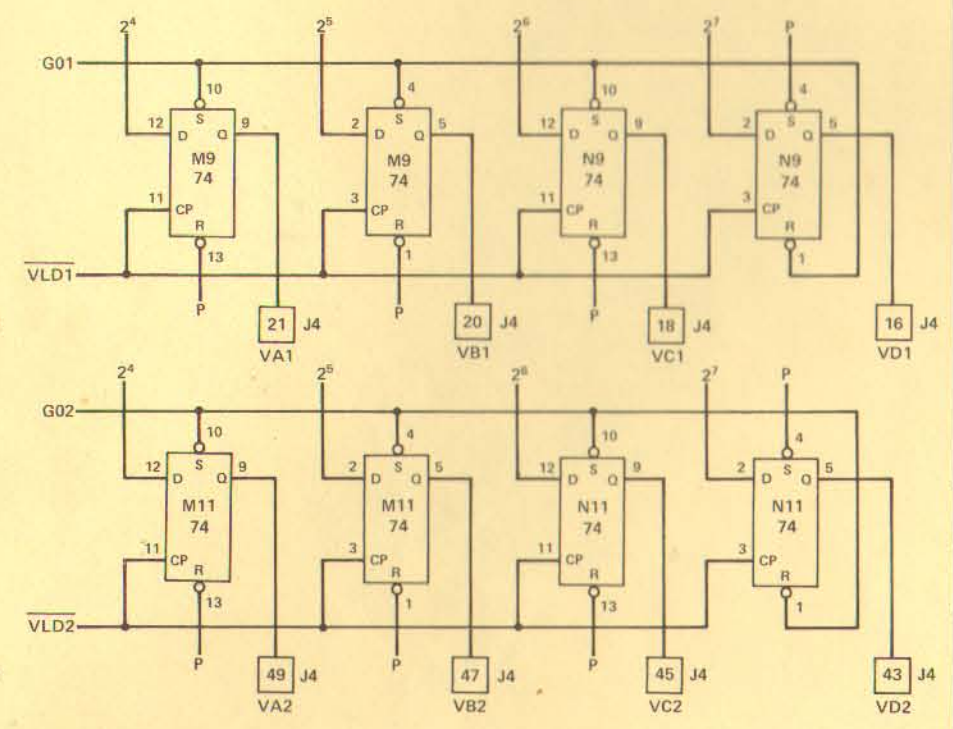
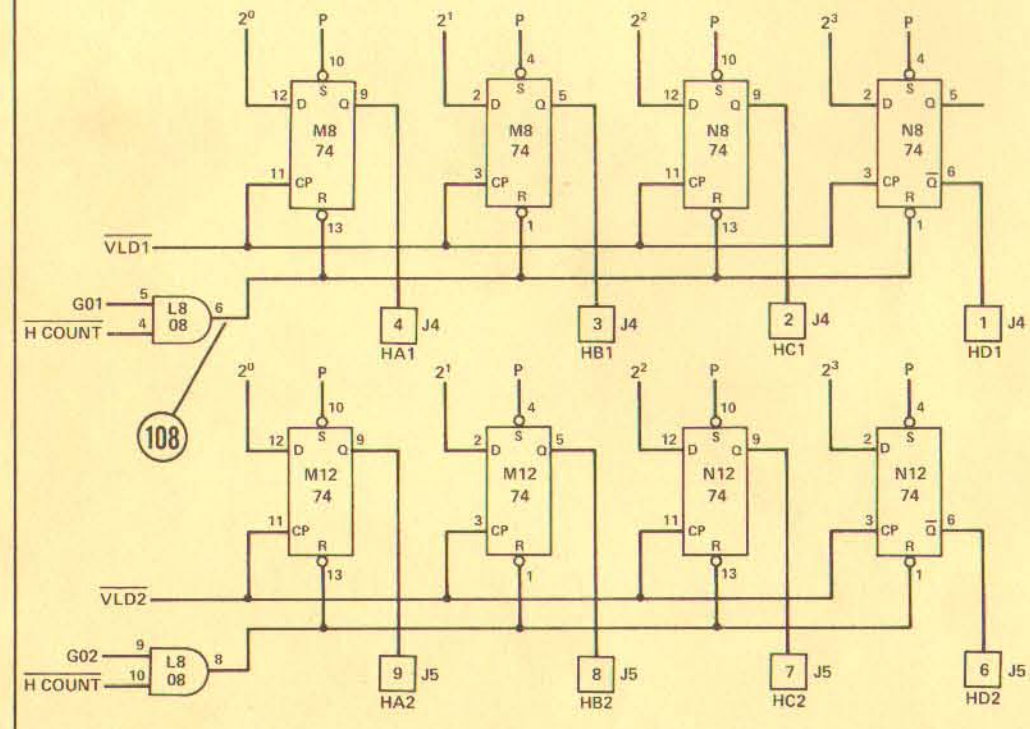
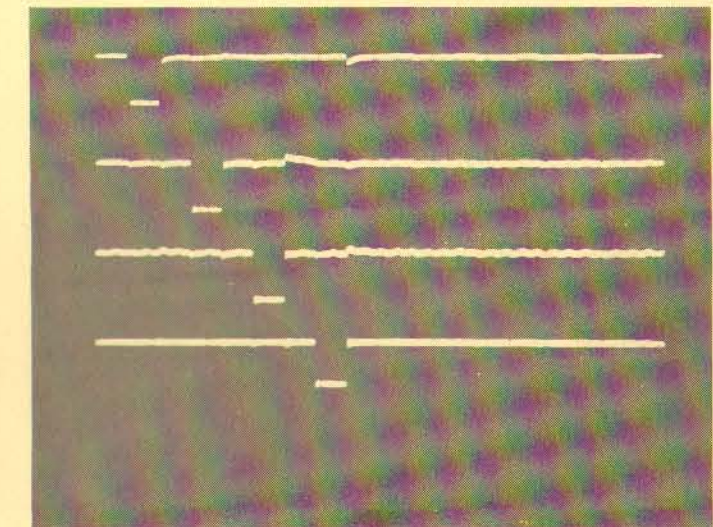

FIGURE 42
HORIZONTAL & VERTICAL MOTION LATCHES



Horizontal Load Signals: This photograph illustrates the timing relationships between LDH1A, LDH1B, LDH2A, and LDH2B (top and bottom). 2 us/div. 5 v/div.

13.3 Vertical Load: V RESET sets the R-S flip-flop composed of gates K11 and the flip-flop is reset 2V later. Since V RESET is HI for one half-line and the R-S flip-flop is reset one line later by 2V, the output at K11-13 is HI for 1½ lines. This signal is inverted and the output at J11-4 controls the other K11 gates. The signal at K11-5 allows one LDH1B pulse through and K11-1 outputs one LDH2B pulse through to form VLD2.

SECTION 14

TANK MOTION

14.1 Motion Latches: These circuits select the motion code data from the mass of ROM data constantly being read out and regulate when codes are changed. The motion code information generated for the different tank aspects in the memory circuit (Section 9.5) is the data input to both sets of motion latches. The control functions are determined by acceleration signals GO1 and GO2, load signals VLD1 and VLD2 and timing signal H COUNT. Each player has a set of both vertical and horizontal motion latches so that tank motion may be controlled separately for each player. Since the circuits are identical for both players, we will analyze the first player's latches only.

14.2 Horizontal Motion Latches: The position information from the ROM appears at the D inputs of the latches only during the time when VLD1 is HI and is clocked through by this signal. However, both the set and reset terminals of all the latches must be HI before they can be clocked by VLD1. The set terminal is permanently tied HI but the reset terminal is controlled by the ANDing of GO1 and H COUNT. Under acceleration, the terminal count of counter H14 in the Tank Control circuit (Sections 6.3 and 6.4) is reached more quickly producing HI GO1 pulses more often. Each HI GO1 pulse lasts for two rising edges of VLD1 since counter H14 is clocked by VLD1. Therefore, VLD1 rises HI in the middle of the terminal count pulse from H14. If GO1 pulses HI and since H COUNT is always HI during this time, the position information is clocked from the ROM into the latches and appears at the latch outputs. This information then becomes the motion code input to the tank motion circuit, however notice that the first three output bits of the latches appear from the Q outputs but that the fourth bit appears from the \bar{Q} output. This has been done specifically so the stop code of 0 0 0 1 (8) will be generated at the beginning of each line so the image can be shifted only once per frame. Otherwise, each line of the image will be shifted causing it to break up diagonally.

14.3 Vertical Motion Latches: The vertical versions are essentially the same except for the fact that since we are dealing with frames rather than lines, the stop code does not need to be loaded every line. If GO1 is LO, the first three flip-flops are preset but the fourth is reset producing the stop code 7 for a number of frames which depends upon the degree of acceleration. When GO1 rises HI, the motion code read from the is loaded and clocked out by VLD1.

14.4 Motion: The illusion of motion is achieved by rapidly shifting the tank and shell images on the CRT in much the same way that the illusion of motion is created on the motion picture screen by the film in the projector. The eye perceives this positional shift as smooth motion because of a phenomenon known as *retinal after-image*. This phenomenon causes the last seen image to be "remembered" for a short period of time and, as the position of the image is shifted a number of times in rapid succession, the eye overlaps the images and the brain interprets the shifting process as continuous motion. This process is enhanced by the *persistence* of the phosphor coating on the inside of the CRT which causes the image to linger, even after the electron beam is moved to a new location or shut off.

The speed or velocity of the image is controlled by the shift/rate frame rate ratio. In other words, if the position of the image is shifted once every frame it will appear to move much more quickly than if it were shifted only once every three frames.

The direction of vector or the moving image is controlled by varying the rate at which the vertical and horizontal motion windows are shifted with respect to each other. As the window in Figure 43a moves up and down, the image contained within it also moves up and down. Figure 43b shows the horizontal motion window which controls the left-right motion of the image. When the two windows are combined, the image at the intersection can be vectored at any angle by individually varying the rates at which the windows are shifted with respect to each other. For example, if the two windows are shifted equally, the resultant vector will be 45° (Figure 43c). But, if the horizontal window is shifted twice as fast as the vertical, the image will move along a 22.5° vector.

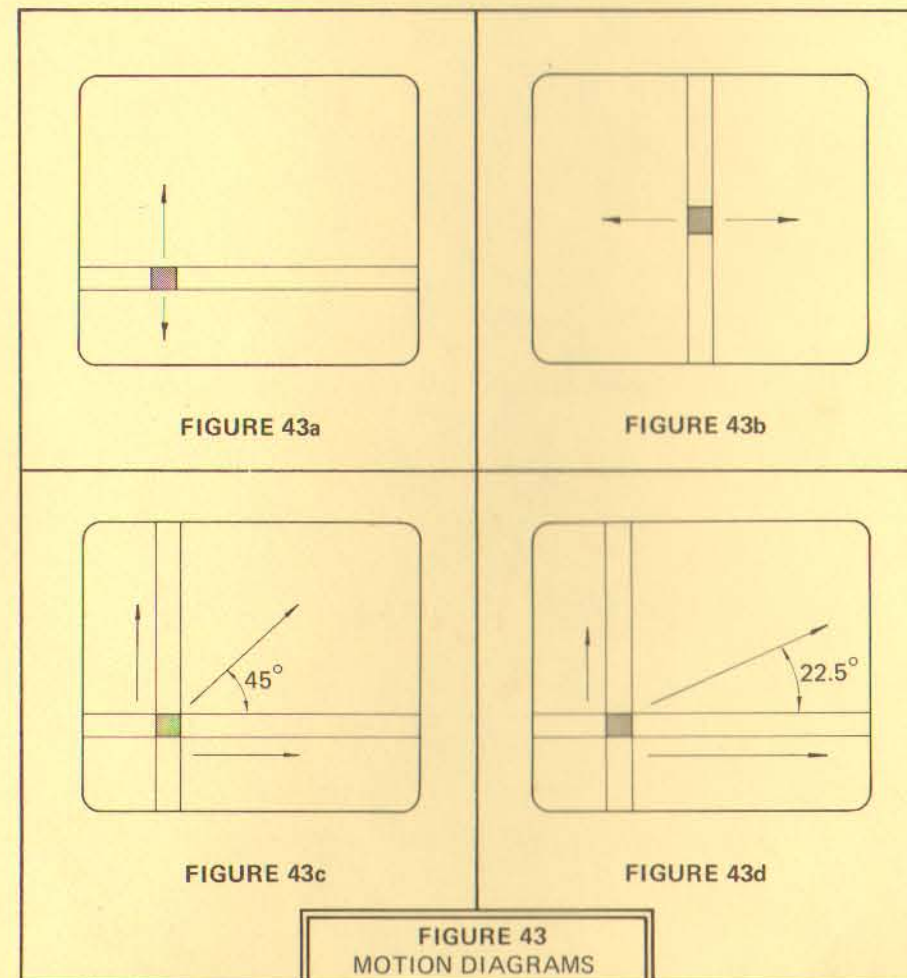

The motion circuits operate by virtue of the "slipping counter" process. You may have noticed that the motion circuits are constructed in much the same way the sync circuits are designed and they run in parallel to their sync counterparts. If the count of the motion circuits is timed exactly with the sync count, the image will be generated in the same place each frame and will appear to be stationary. However, if the motion circuits are directed to develop their outputs a little sooner or later with respect to sync, the resulting window will be shifted an amount equal to

that differential and will appear to move. For example, if the horizontal motion chain is advanced one clock pulse with respect to horizontal sync, the image will be generated one clock pulse to the left each frame and will appear to move in a leftward direction.

The differential is controlled by loading different codes at the parallel inputs of the motion counters so that the count at which these counters begin may be varied to produce different velocities and vectors. The "stop code" is that number which synchronizes the motion chains with the sync chain and causes a cessation of motion. Other codes, both higher and lower, cause a change in this relationship so the position of the image is shifted with respect to sync.

14.5 Tank Motion Circuits: Since the tank image must be capable of movement in both the vertical and horizontal dimensions, there must be both vertical and horizontal motion circuits. And, since there are two players, there must be a complete set for each player. Furthermore, since parallel ROM data is used for the image, there must also be provisions for serializing the final output. Both player's motion circuits are absolutely identical, so the following discussion will cover those for the first player only.

Horizontal tank motion is controlled by the chain constructed from counters A1 and B1 and flip-flops N1. This chain generates THW1 (Tank Horizontal Window for player 1) which is the horizontal motion component. Vertical motion is achieved by changing the input to the vertical chain composed of A2, B2 and C2 which generates the vertical tank window. The two windows are combined at flip-flop F3 and this signal enables shift registers A3 and B3 to shift out the proper tank image in the correct area of the CRT.

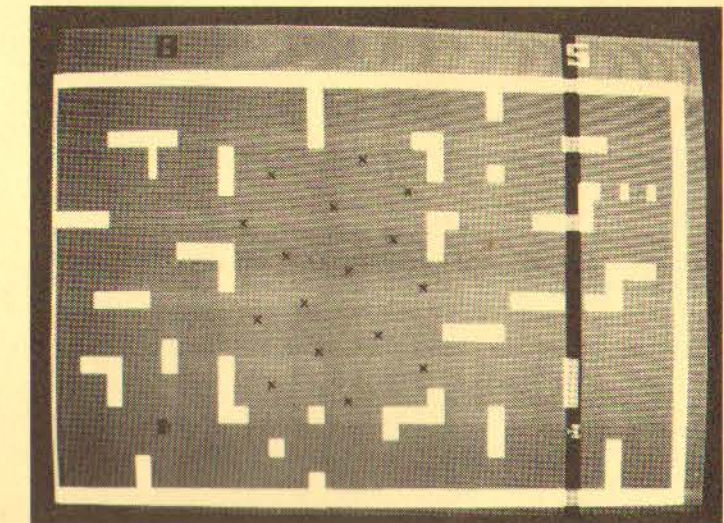

THW1: This vertical window controls the horizontal position of the white tank. As this window moves in the left-right dimension, the tank image contained within it is also moved.

14.6 Horizontal Tank Motion: The motion code outputs, (HA1, HB1, HC1 and HD1) from the motion latches (Section 15.3) are entered at the parallel inputs of 9316 counter A1. This type of counter is used be-

cause it is capable of being preset to a given number and will count up from that number when the parallel entry terminal (PE) pulses HI. Counter B1 is permanently loaded with the base number 112 ($64 + 32 + 16$) and since the entire chain is ten bits long, a full count of 1024 is possible. However, since B1 is preloaded with 112, the maximum count is actually $1024 - 112$ or 912. Remember that each line of the raster contains 904 clock pulses including both resets. Therefore, the number loaded into counter A1 which stops motion is $912 - 904$ or 8.

The signal GO1 determines how often the motion code is loaded, hence GO1 controls the shift rate/frame rate ratio. The more often GO1 pulses HI, the more times the code will be loaded and the image will move more quickly. The particular motion code entered is a function of which tank image is displayed. For example, if the tank is rotated so it faces in a leftward direction, the motion code of 9 is retrieved from memory and

the count of the horizontal chain will be advanced one clock pulse with respect to sync causing the image to move left. Now, if the tank is under the greatest acceleration, the same is entered more often which will cause the image to be shifted a greater number of times.

The new code is loaded by $\overline{\text{THR}}$ 1 which pulses HI on the 1023rd count ($15 + 240 + 512$) so the number is actually loaded between the 1023rd clock pulses. $\overline{\text{THW}}$ 1 includes all the elements which make up $\overline{\text{THR}}$ 1 except the terminal count from A1 (15), so it drops LO from 1008 to 1024 producing a 16H wide window in which the tank image appears.

14.7 Vertical Tank Motion: Since there are three four-bit counters in this chain, it can count a total of 2^{12} times (4096). However, the base number 3568 is tied into B2 and since the chain must start from this number, it can actually only count 528 pulses since $4096 - 3568 = 528$.

Since there are a total of 521 half-lines per field, the stop code is 528-521 or 7. The new number is loaded when $\overline{\text{TVR}}$ 1 pulses LO between 4095 and 4096, however the 16V wide window is generated between 4080 and 4095 when TC of C2 rises HI.

14.8 WINDO 1: The vertical and horizontal motion windows are combined at flip-flop F3 to generate a composite and final tank motion window (WINDO 1). The flip-flop is enabled when TC of C2 pulses HI which appears as a white, vertically movable horizontal bar. This enables the LO at $\overline{\text{THW}}$ 1 to be clocked through F3. Since $\overline{\text{THW}}$ 1 is a dark, horizontally movable vertical window, the result at F3-9 is a small black square (WINDO 1) occurring at the intersection of the vertical and horizontal windows.

14.9 Tank Display: The tank aspect data is loaded into shift registers

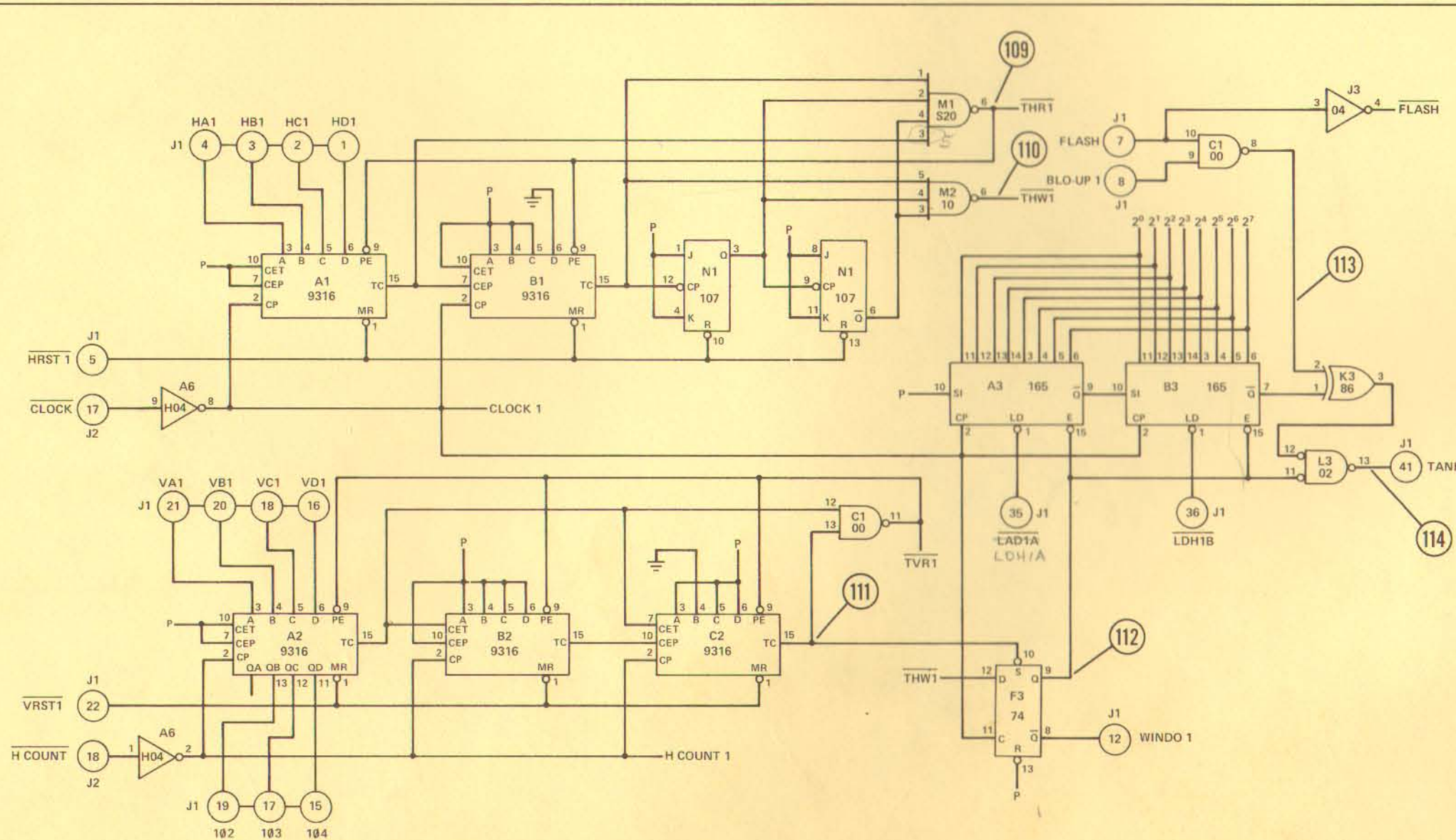

FIGURE 44
TANK 1 MOTION CIRCUIT

- 109. Logic Probe: HI and Pulsing.
Video Probe: Dark vertical line moving with tank.
- 110. Logic Probe: HI and Pulsing.
Video Probe: Dark vertical column over tank and moving with tank.
- 111. Logic Probe: HI and Pulsing.
Video Probe: Light horizontal bar over tank and moving with tank.
- 112. Logic Probe: HI and Pulsing.
Video Probe: Dark square over tank and moving with tank.
- 113. Logic Probe: LO going to a slowly changing signal when tank is blown up.
- 114. Logic Probe: LO and Pulsing.
Video Probe: Intensifies tank image.

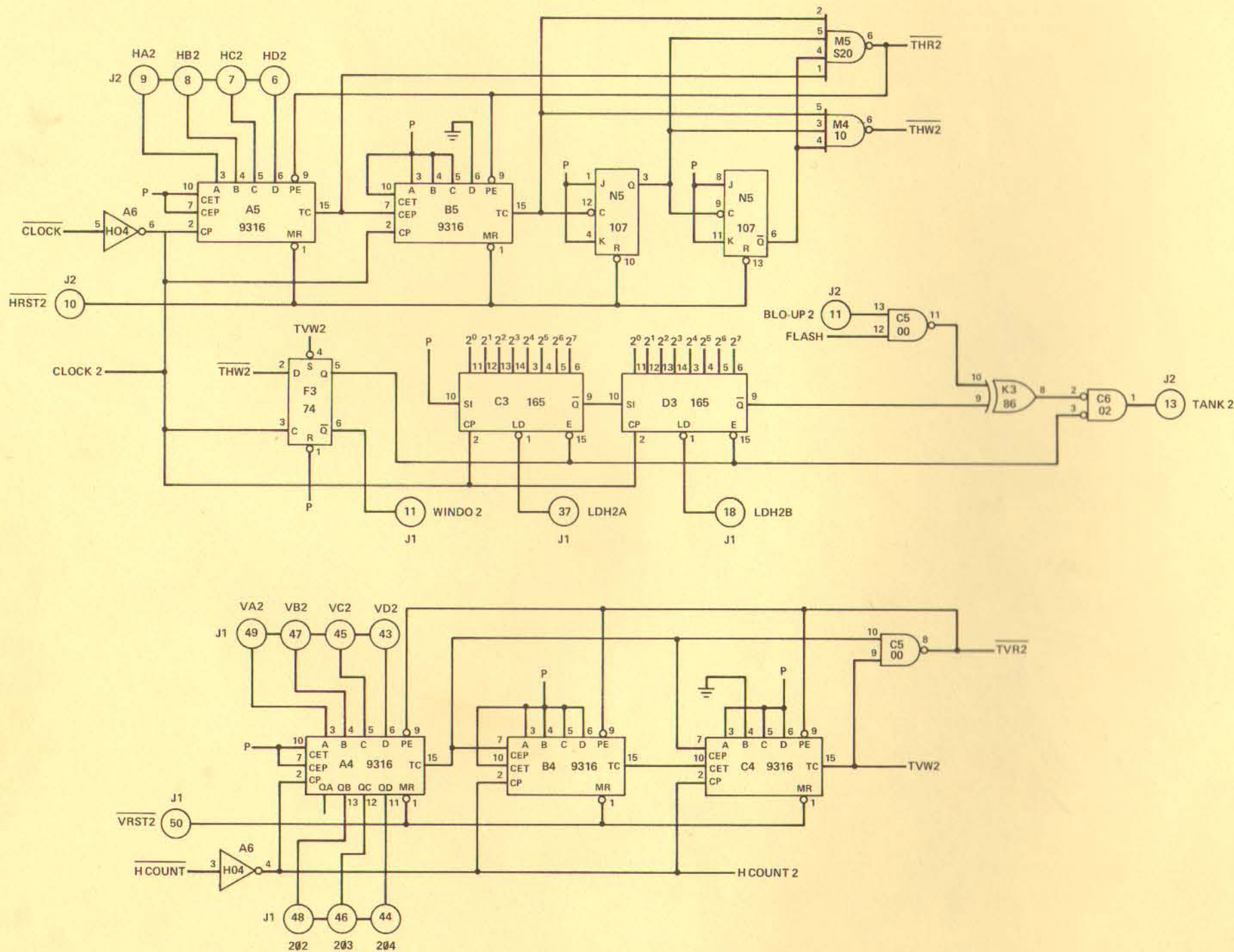
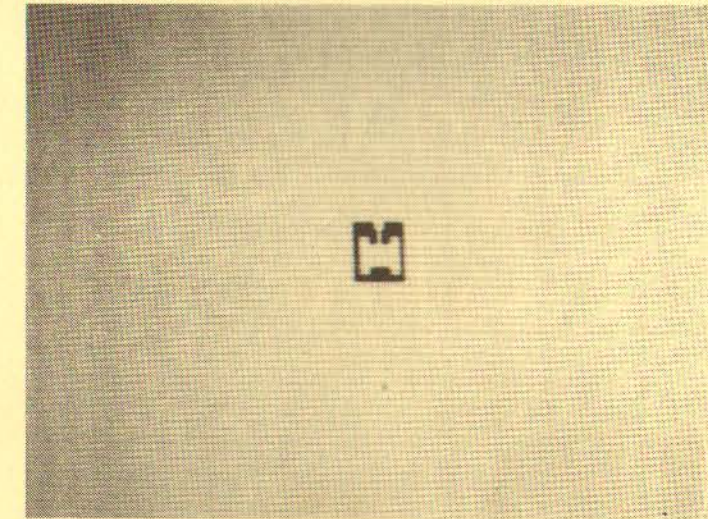

FIGURE 45
TANK2 MOTION CIRCUIT

A3 and B3 by $\overline{\text{LDH1A}}$ and $\overline{\text{LDH1B}}$, which occur concurrently with the output of the aspect data from the ROM. This data is clocked out serially when enabled by WINDO 1 and the result is the tank image positioned within a window no longer visible. Two 8-bit shift registers are used because the tank is 16 bits wide so each register is responsible for the information in one half of the window. This is easily visualized by holding A3-9 LO and preventing the second half of the information coming through.



Blown-Up Tank Aspect: The tank appears to explode because both the image and the window are rapidly inverted. The window for the black tank is normally not visible and contains a black tank image. This photograph illustrates the inverted aspect of the image and window.

During a game, if the second player fires a shot and hits the first player's tank, BLO-UP 1 pulses HI and enables FLASH to invert the tank image at K3. Normally, however, the white tank image is passed and gated with the tank window at L3 and there is a specific reason for gating these two signals together. Since the serial input of the shift register is tied HI, the 17th bit out of the register will be LO and produce a series of annoying white bars on the CRT. These are eliminated by gating the signal with the tank window.

SECTION 15
SHELL MOTION

15.1 Construction: A number of circuits are needed to operate the shell firing feature and most of these circuits share similarities of function and construction with their tank motion counterparts. There are both vertical and horizontal motion circuits for each player where each motion circuit is again controlled by a set of motion latches. The images used for the shell and the explosion are generated in this circuit whereas the tank images are stored in the ROM.

15.2 Horizontal Shell Motion Latches: The tank position information is used not only to control tank motion but to aim the shell as well. This

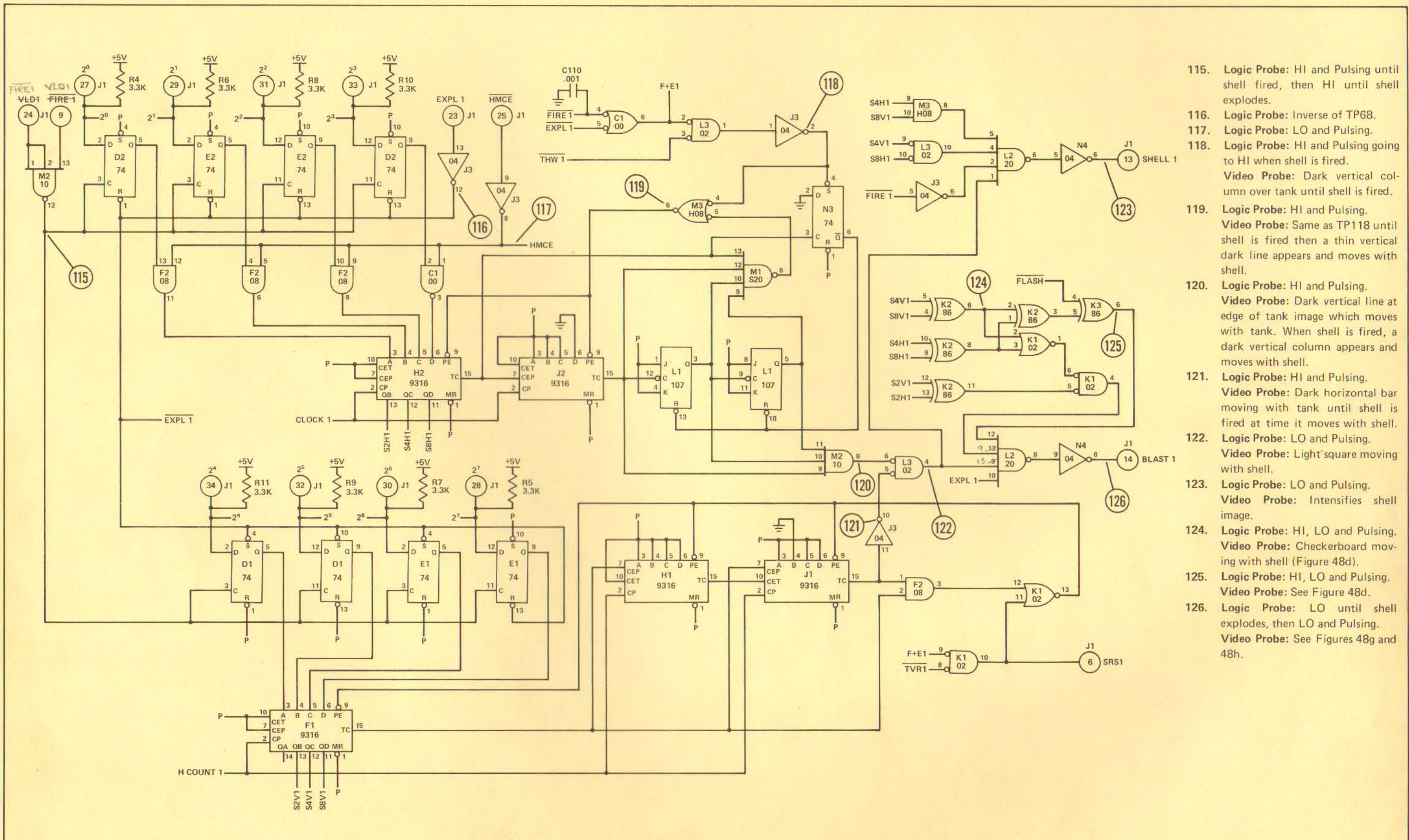

FIGURE 46
SHELL 1 MOTION CIRCUIT

- 115. Logic Probe: HI and Pulsing until shell fired, then HI until shell explodes.
- 116. Logic Probe: Inverse of TP68.
- 117. Logic Probe: LO and Pulsing.
- 118. Logic Probe: HI and Pulsing going to HI when shell is fired.
Video Probe: Dark vertical column over tank until shell is fired.
- 119. Logic Probe: HI and Pulsing.
Video Probe: Same as TP118 until shell is fired then a thin vertical dark line appears and moves with shell.
- 120. Logic Probe: HI and Pulsing.
Video Probe: Dark vertical line at edge of tank image which moves with tank. When shell is fired, a dark vertical column appears and moves with shell.
- 121. Logic Probe: HI and Pulsing.
Video Probe: Dark horizontal bar moving with tank until shell is fired at time it moves with shell.
- 122. Logic Probe: LO and Pulsing.
Video Probe: Light square moving with shell.
- 123. Logic Probe: LO and Pulsing.
Video Probe: Intensifies shell image.
- 124. Logic Probe: HI, LO and Pulsing.
Video Probe: Checkerboard moving with shell (Figure 48d).
- 125. Logic Probe: HI, LO and Pulsing.
Video Probe: See Figure 48d.
- 126. Logic Probe: LO until shell explodes, then LO and Pulsing.
Video Probe: See Figures 48g and 48h.

data occurs concurrently with VLD1 which clocks the position information through flip-flops D2 and E2 until the shell is fired. At this point, FIRE 1 drops LO so the flip-flops can no longer be clocked and they output the last tank code before the fire button was pressed. All the flip-flops are reset by EXPL 1 when the explosion occurs, but more about this last event in a moment.

The outputs from the previous flip-flops enter gates F2 and C1 along with HMCE (Section 5.4). When the shell is fired, FIRE 1 drops LO the last motion code is dropped into the counter chain by HMCE and the stop code is loaded for the rest of the field. When the shell explodes, EXPL 1 drops LO, the flip-flops are all reset and output LOs to gates F2 and C1. But since the output of C1 is inverted, a stop code of 0 0 0 1 (8) is generated which stops shell motion during the explosion sequence so the explosion image will be stationary.

15.3 Horizontal Shell Motion: The counter chain itself operates exactly like the tank motion chain except when the shell is not being fired. While the shell is not being fired, FIRE 1 and EXPL 1 are both HI and C1-6 is LO (F+E 1) enabling THW1 through L3. The function of THW1 is to position the shell within the tank window so it appears from the tank when fired. It does this because since it is used for the parallel entry of the counter chain, the chain can only start counting from the last position of the tank. This signal also presets flip-flop N3 producing a LO from the Q output which resets flip-flops L11 in the counter chain.

The 16H wide horizontal window used both for SHELL 1 and BLAST 1 and is developed at M2-8 by the addition of 512, 240 and 256 which equals 1008. So, the window actually extends from 1008 to 1024 and this signal is gated with the vertical component at L3.

15.4 Vertical Shell Motion Latches: The same signal from M2-10 performs the same functions of clocking or not clocking vertical flip-flops D1 and E1. It therefore loads the tank motion code until FIRE 1 drops LO at which time the last code is dropped in the latches and appears at the parallel input of the counter chain. But when the explosion occurs, EXPL 1 drops LO presetting the first three flip-flops so their Q outputs are all HI and resetting the fourth so its Q is LO. The result at the chain is a stop code of 1 1 1 0 or 7 which freezes shell motion and allows the explosion images to be displayed where the shell hit.

15.5 Vertical Shell Motion: The counter chain for vertical shell motion is a 12-bit chain exactly like the one for vertical tank motion. Since it works identically, no further discussion is needed. The result is a vertical shell window occurring from 4080 to 4095 which provides a 16V wide window in which all the explosion video occurs.

15.6 SRS 1: TVR 1 loads the motion code through K1 only when F+E 1 is LO so that the shell window follows the tank vector. SRS 1 is the signal used to position the shell in the tank vertically and to prevent the firing of a second shell while the first is still in flight.

15.7 SHELL 1: This portion of the circuit produces the little square used to display the shell. First, S4H1 is ANDed with S8V1 producing the pattern in Figure 47a. S4V1 and S8V1 produce a similar pattern, except vertical in nature (Figure 47b). When the two are combined (Figure 47c), the result is that small, slightly offset area where both Figures 47a and 47b are HI.

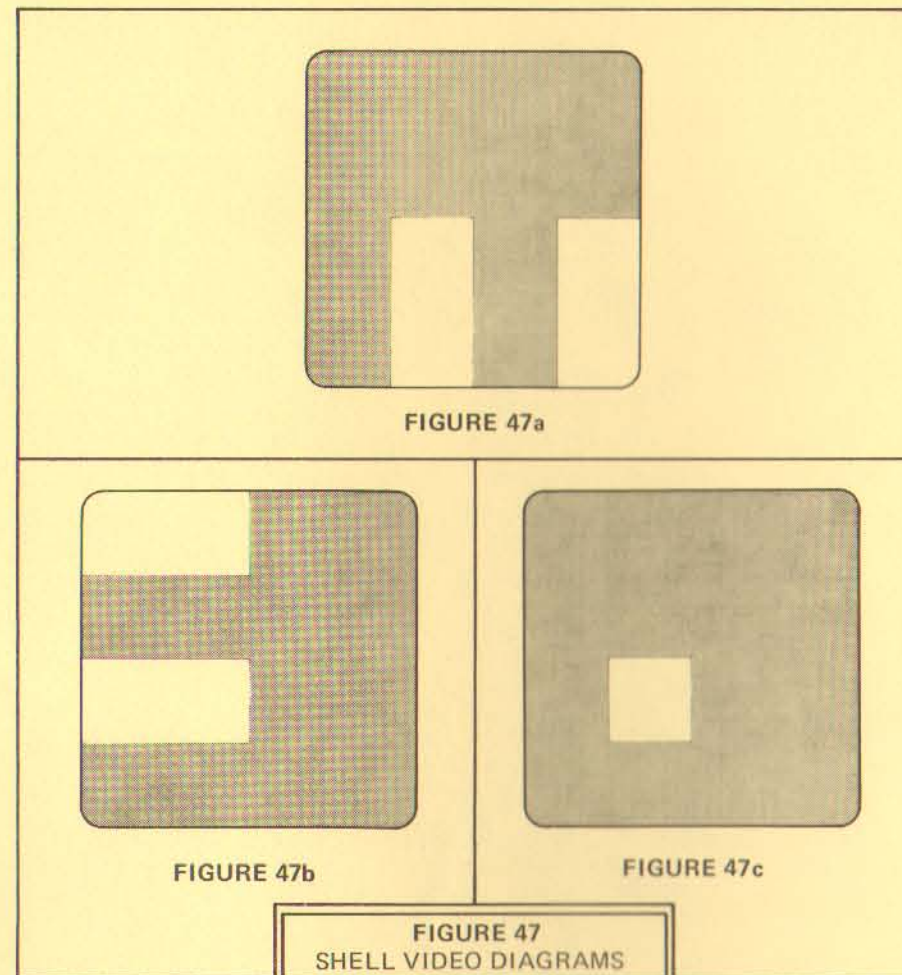

15.8 BLAST 1: This section generates two differently sized explosion displays which are rapidly alternated to produce a realistic explosion. First a checkerboard is generated by exclusively ORing S2V1 and S2H1 (Figure 48a). Then a set of vertical bars is generated with S4H1 and S8H1 (Figure 48b) as well as a set of similar horizontal bars (Figure 48c). Exclusively ORing Figure 48b with Figure 48c at K2-2 generates the pattern illustrated in Figure 48d. This last signal is exclusively ORED with FLASH, the control input which alternates the two explosion displays. Figure 48e is generated using 48b and 48c in a similar fashion as 48d is developed and is gated with 48a to produce the information in Figure 48f. When 48f is gated with 48d or its inverse, the result are explosion displays 48g and 48h. During the time FLASH is LO, 48g results and 48h occurs when FLASH returns HI quickly thereafter. However both these explosion displays are enabled only when EXPL 1 at L2-10 pulses HI (explosion occurs) and then only where the shell window is because L3-4 is connected at L2 as well.

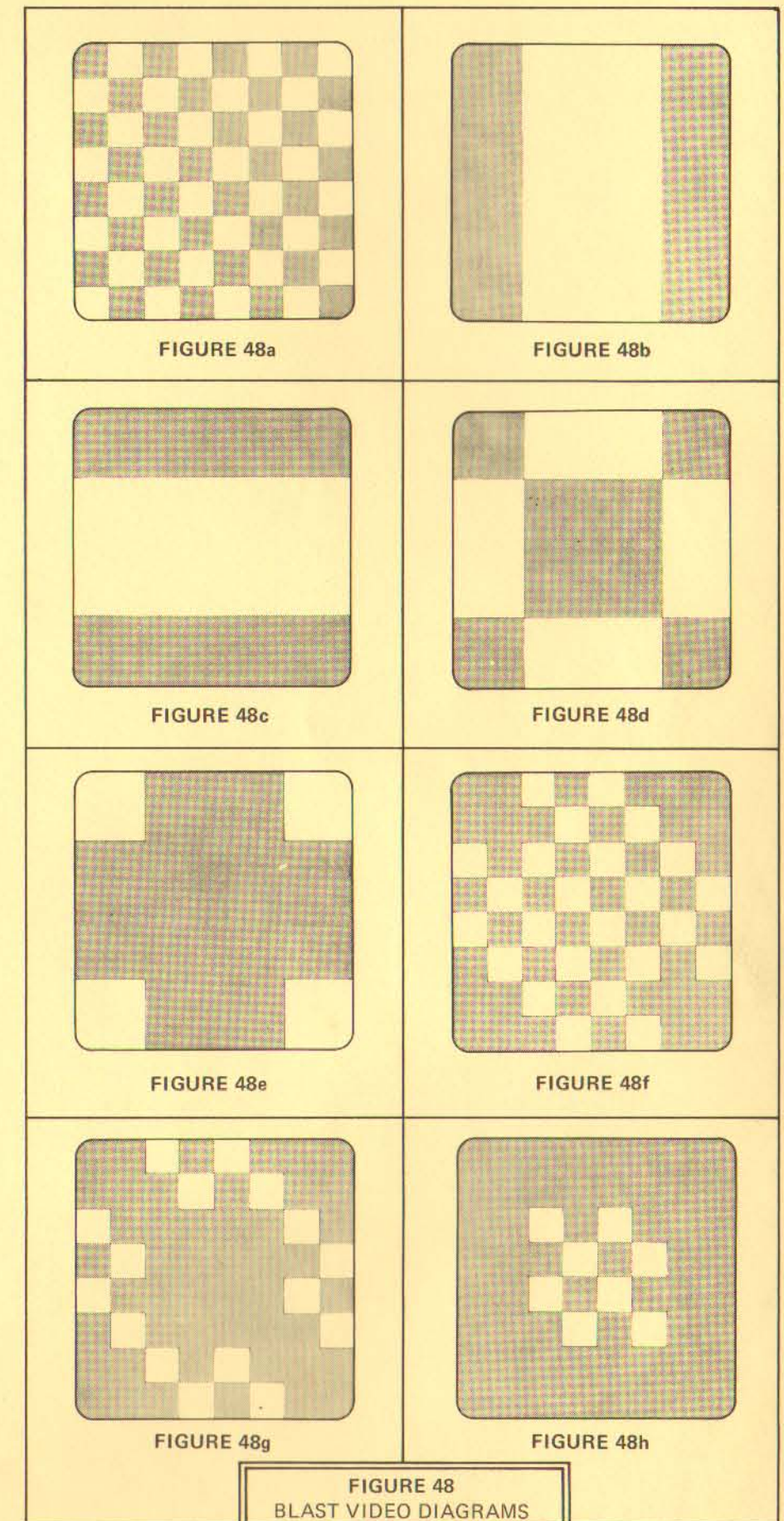

SECTION 16

SOUND CIRCUITRY

16.1 Function: Since a number of events require separate and realistic sounds, quite a bit of circuitry is required to create an adequate reper-

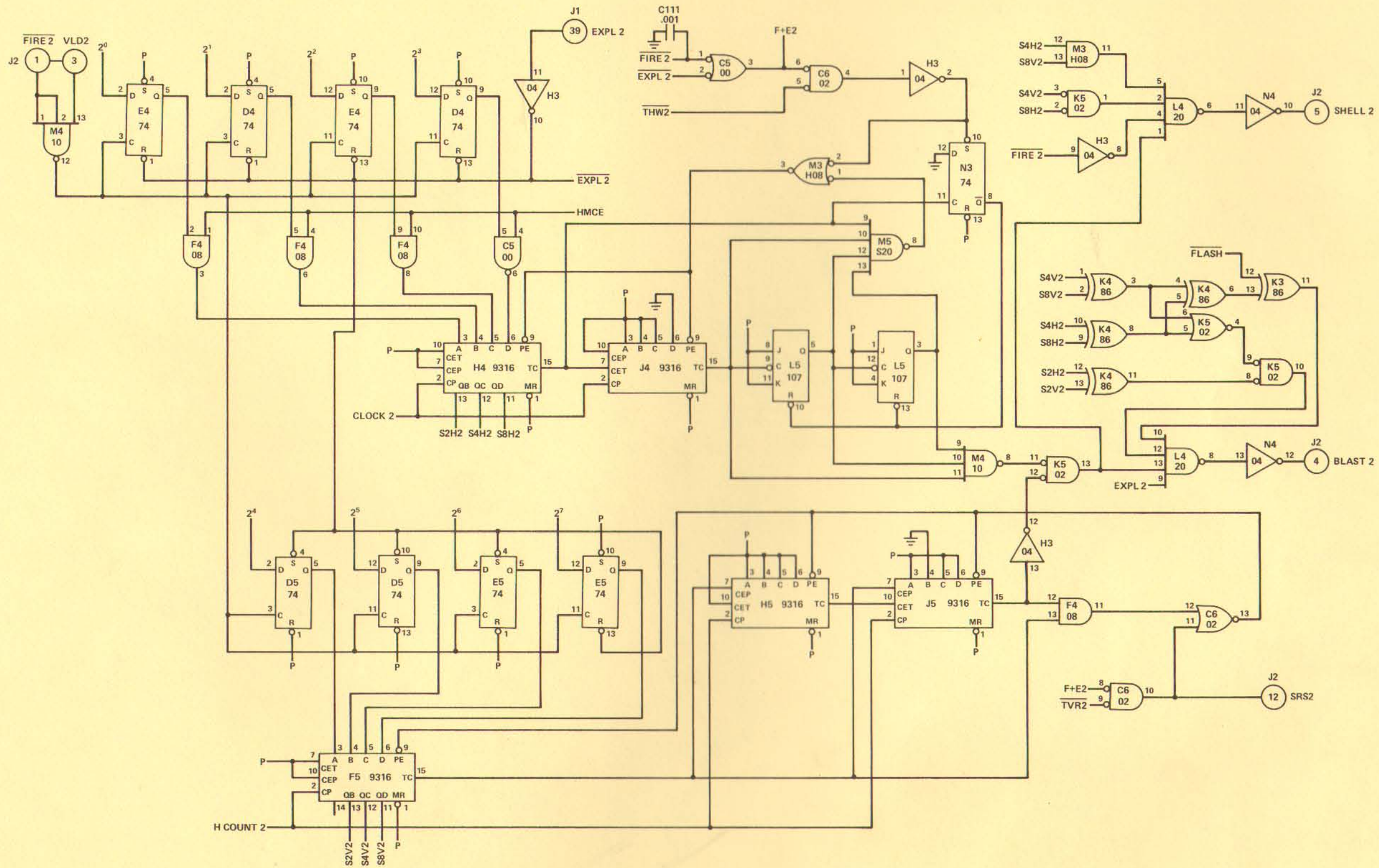
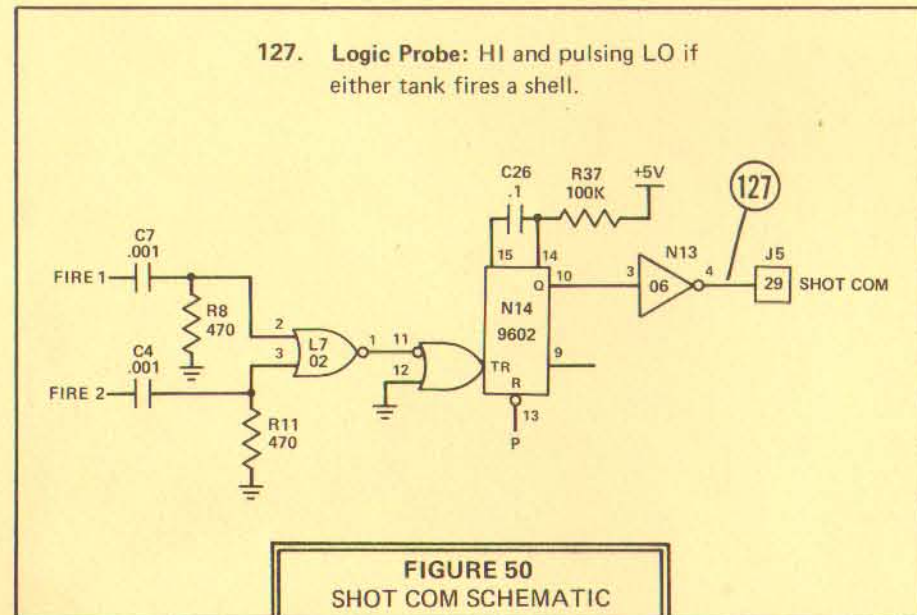

FIGURE 49
SHELL 2 MOTION CIRCUIT

toire of noises. Each player's tank motor sound must be generated and controlled separately so that engine RPM will reflect the speed of the tank. However, since no such relationship exists for the shot and boom sounds, they can be generated in common for both players. However, since both do share common generation, adjusting the volume affects the final shot and boom sound outputs for both players.

16.2 SHOT & BOOM COM: These two circuits are used in common for both players, hence the names SHOT COM and BOOM COM. They produce timed intervals which regulate the length of the shot and boom sounds. The combination of the RC network attached to the 9602 one-shots limit the sound duration to about 3 ms.

16.3 SHOT COM: If either player presses his fire button, FIRE 1 or FIRE 2 pulses HI. This signal is processed by the differentiator composed of C4 and R11 or C7 and R8 which reduces the pulse to a spike of very short duration. The resulting LO pulse from L7-1 triggers one-shot N14 which outputs a pulse known as SHOT COM in its inverted form.



16.4 BOOM COM: Signals EXPL1 and EXPL2 contain pulses where the period represents the length of shell travel. These signals are gated with MTK 1 or MTK 2 which occur when the tanks encounter a mine. If any of the inputs to L7 pulses HI, L7-10 or L7-4 drops LO producing a HI from K7. This HI triggers one-shot N14 and the inverted timed output pulse is known as BOOM COM.

16.5 NOISE: The only function this circuit has is to generate a raw noise waveform which is further processed and refined in both SHOT and BOOM sound circuits to develop more acceptable noises.

Transistor Q5 generates the initial noise waveform by virtue of its avalanche characteristics which is why each one is specially selected for its zener voltage and the sharpness of the "knee" (the point at which the current curve turns and shoots upward). Only the 2N3643s with the sharpest knees are used.

A small amount of current (about 18 μ A) is passed through the 680K resistor, turning on the transistor and beginning the avalanche. However, since the transistor draws current, the zener voltage is quickly reached turning off the transistor and halting the avalanche. This rapidly repeating process generates the raw noise waveform which is coupled through C40 to the non-inverting input of the 741 opamp. This opamp acts both as an

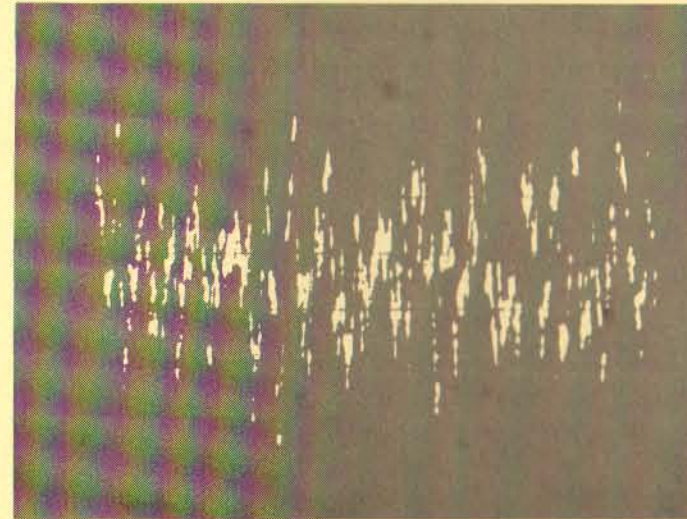

NOISE: This random white noise waveform is used in the development of other, more refined sound waveforms. 10 ms/div. 2 v/div.

amplifier and a filter where R69, C39 and C38 provide a certain amount of high frequency filtering.

16.6 Shot Sound: This circuit produces the actual noise which accompanies the shell leaving the gun. First, NOISE must pass through a 50K trimpot which controls the amplitude of this signal and hence the volume of the final shot sound. NOISE is also filtered by C32 which eliminates more of the higher frequencies before it is coupled to the 6040 attenuator. The attenuator is an electronic volume control operated by the voltage at control pin 2.

When SHOT COM drops LO (the shell fired), C28 is discharged through CR19 turning on Q7 and causing a drop in voltage at the attenuator control pin which then passes a greater amount of NOISE. When SHOT COM returns HI, C28 charges through R64, Q7 turns off and the voltage at pin 2 rises. Less sound is then allowed through the attenuator until it is silenced altogether. The final result is a shot sound waveform containing a single burst of NOISE.

16.7 Boom Sound: This circuit is identical to Shot Sound in function and differs in construction by only two small value changes. The value of the coupling cap has been changed to allow more of the low frequencies of NOISE through to achieve a "boomier" effect. Also, the value of the time constant formed by R72 and C41 has been made longer to lengthen the decay so that the resulting explosion sound is lower pitched and lasts slightly longer than the shot sound.

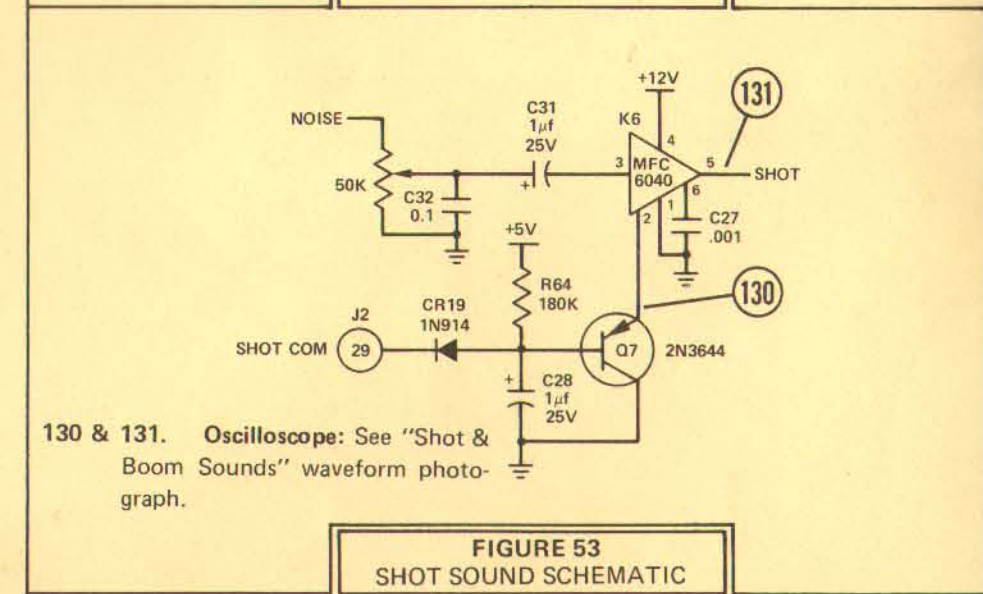
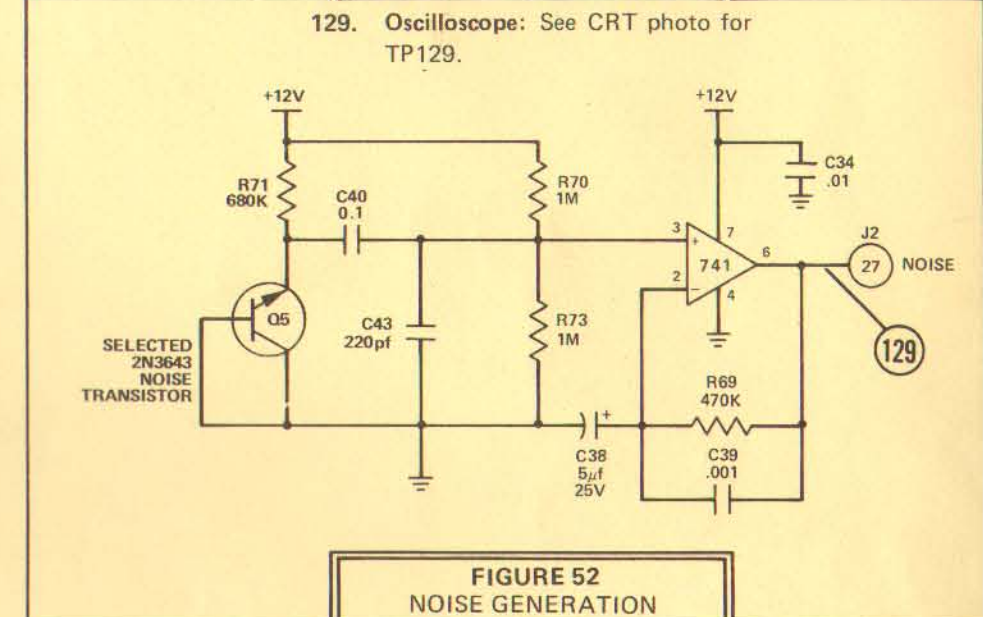
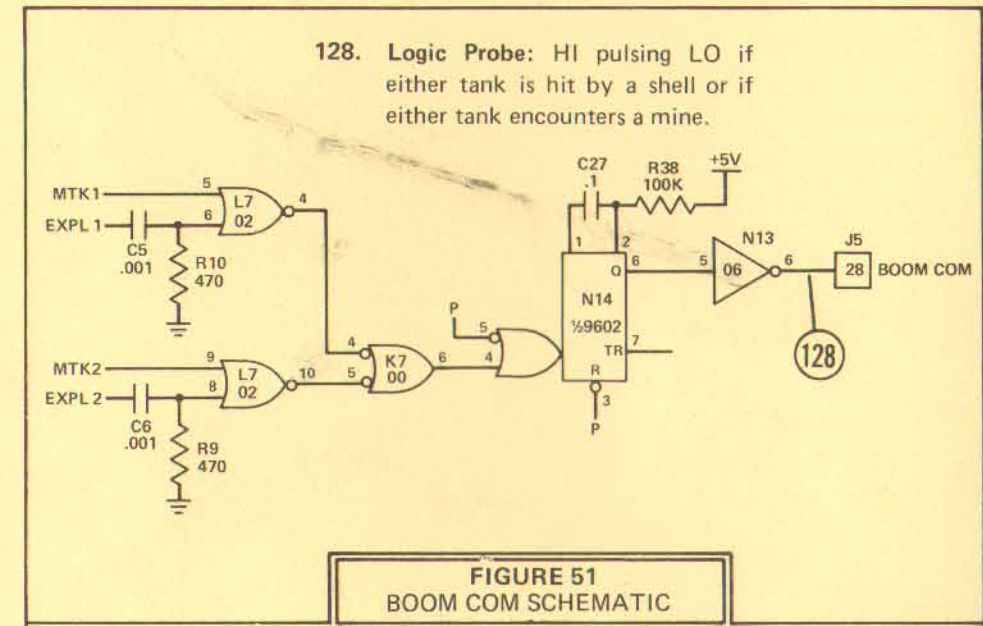

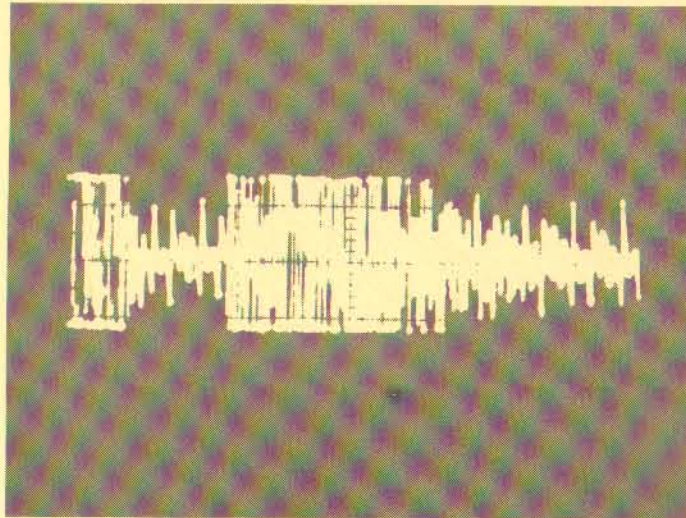

Shot & Boom Sounds: This photograph illustrates both the SHOT (top) and the BOOM (bottom) sound waveforms and timing relationship between the two. Notice that the SHOT waveform is rolled off much more sharply than BOOM so that it has a very sharp attack and decay to produce a realistic shot sound. The BOOM waveform, however, is given a longer decay so the sound lingers very slightly.

The emitter-follower transistor Q27 always draws a certain amount of current through R73. More or less of this current is drawn off as the tank picks up speed by the states of the tank velocity signals 1SP0, 1SP1 and 1SP2. These signals form codes at the inputs of the open-collector inverters K15 which count from 0 0 0 to 0 1 1. As the tank picks up speed and the count rises, more current is drawn from the base of Q27 which turns on Q28 harder and enables the timing capacitor C51 to charge more rapidly. Since 555 timer L15 is wired in the astable configuration, it begins to oscillate faster. The positive plate of C51 is also connected to the base of Q29 which is wired as another emitter-follower. The emitter of Q29 is coupled through C56 to the input of the attenuator placing a sound waveform at this input which oscillates in direct proportion to tank velocity.

The base of Q28 is also connected to the control input of the 566 function generator and as the base drops, the 566 oscillates more quickly. The output of the 566 enters the control pin of the attenuator along with the voltage passing through the 10K trimpot and increases the modulation of the waveform at input pin 3 in proportion to the velocity of the tank and the setting of the modulation adjustment pot.

However, when the game ends, ATTRACT goes HI and N13-2 is pulled down to a logic LO level turning Q30 on. Q30 conducts +12 volts directly through to the control pin of the attenuator and turns it off completely.

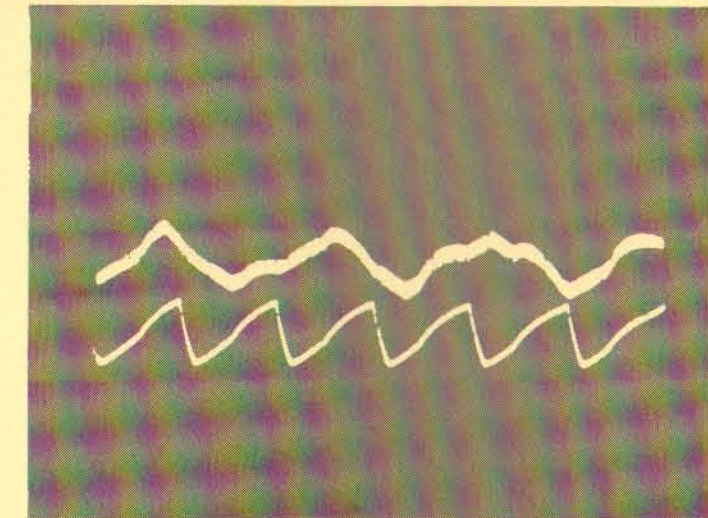

Motor Rate & Modulation: Motor modulation (top) is contrasted to rate (bottom). The modulation trace was photographed with AC-coupling at 5 ms/div. and 500 mv/div., however the scope was DC-coupled for the rate trace and set to 5 ms/div. and 1 v/div.

132 & 133. Oscilloscope: See "Shot & Boom Sounds" waveform photograph.

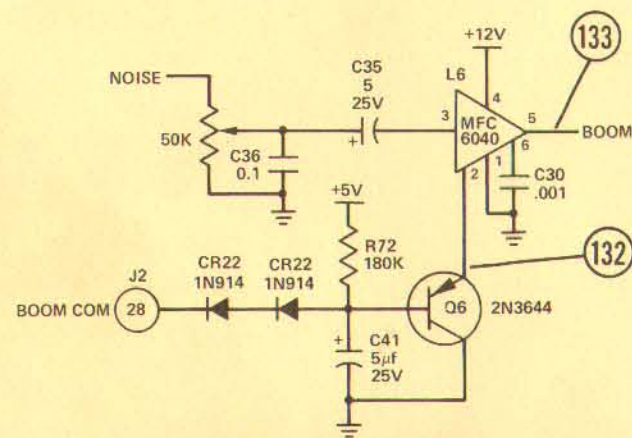

FIGURE 54
BOOM SOUND SCHEMATIC

16.8 Motor Sounds: As mentioned before, each player's motor sound is generated separately so that the engine RPM sound increases or decreases along with the velocity of the tank. Both player's circuits are absolutely identical, so only one will require analysis here.

The circuit in Figure 55 generates a noise waveform where 555 timer L15 controls the noise rate and 566 function generator M15 modulates that rate by changing the control input to 6040 attenuator N15 which is also used to turn off the sound when the game is over.

134. Logic Probe: See truth table which illustrates how the count in varies the voltage at TP 134. Please be aware that your readings may vary by ±5%.

135-137. Oscilloscope: See "Motor Rate & Modulation" waveform photograph.

138. Oscilloscope: See "Final Sound Output" waveform photograph.

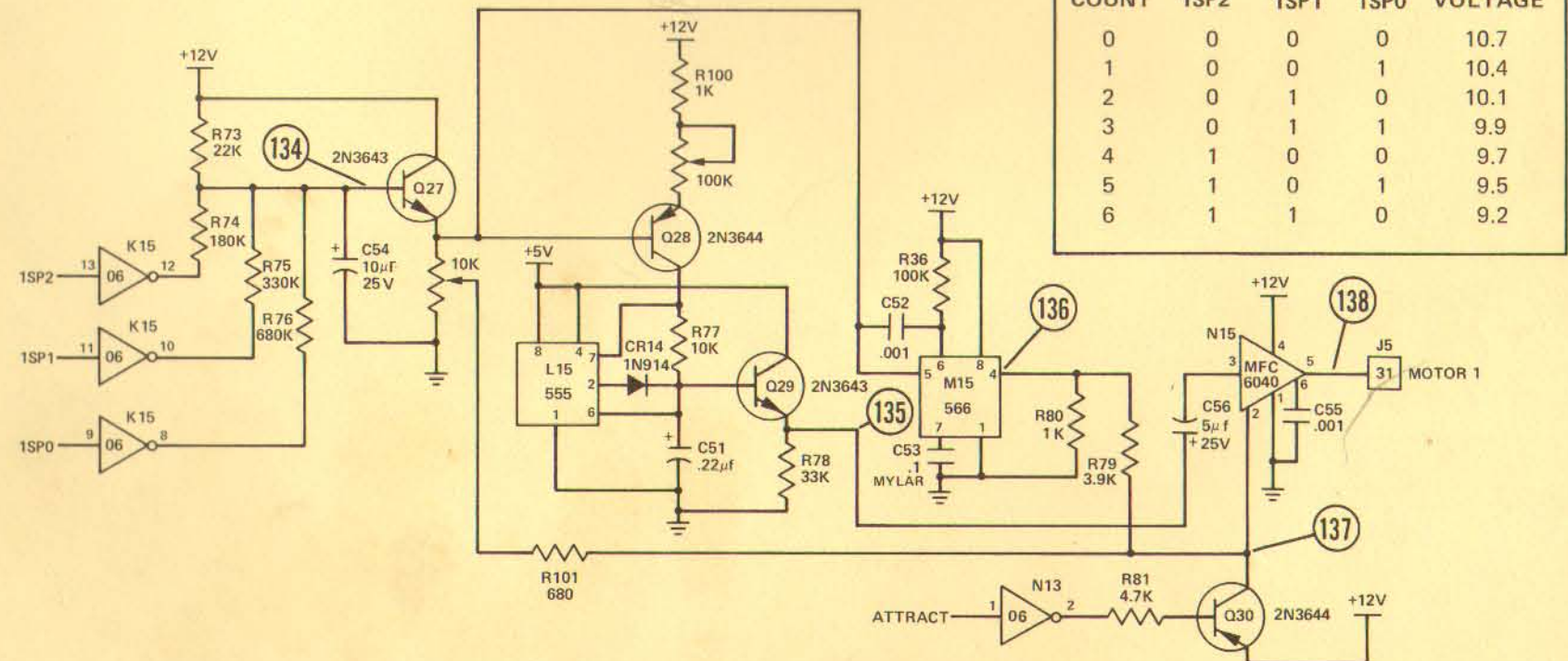
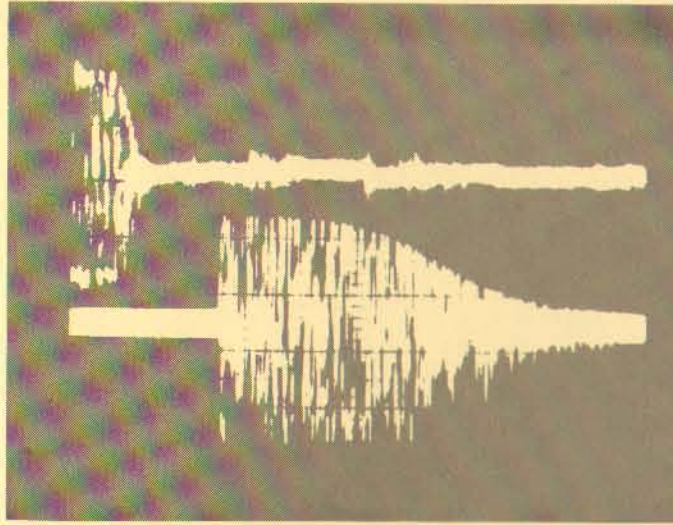

FIGURE 55
MOTOR 1 SOUND SCHEMATIC

16.9 The Audio Amplifiers: Since it is possible for the gains of the two motor sound circuits to be slightly different, there must be two separately adjustable audio amplifiers to insure that the final sounds for both players can be adjusted closely together. Since both player's circuits are identical, we need analyze only the one for the first player.

The first player's three sounds (MOTOR 1, BOOM and SHOT) are summed across resistors R102, R103 and R104 and first pass through a 10K trimpot before amplification. The trimpot controls the amplitude of the signal at this point, hence the final amplified output of this circuit. The noise waveform then enters the amplifier through pin 2 and the gain of this amp is internally set to 50. C102 and R105 filter out some of the high frequencies because at frequencies above 33KHz, the reactance of C102 becomes smaller than the resistance of R105 so part of the noise waveform is coupled through to the inverting input of the amplifier. This causes the high frequencies of the waveform to be attenuated.



Final Sound Output: In this illustration, the shot noise burst is at the left, the boom sound burst appears in the center and the motor sounds occur before and after the boom sound.

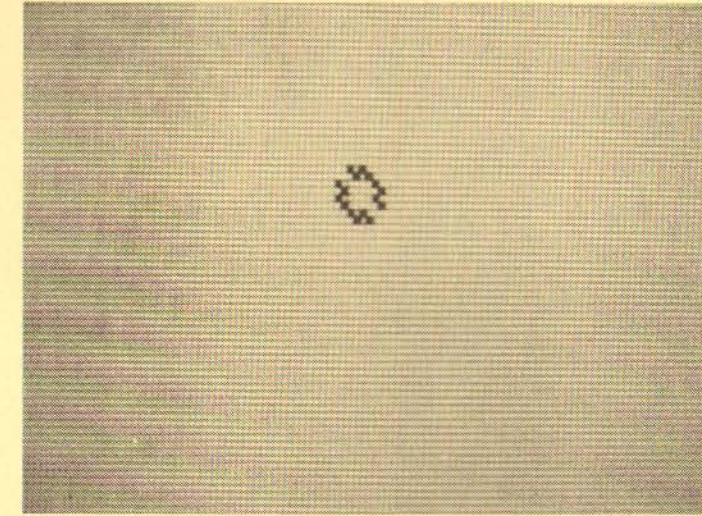

Blast Video: This photograph illustrates the larger of the two BLAST video displays.

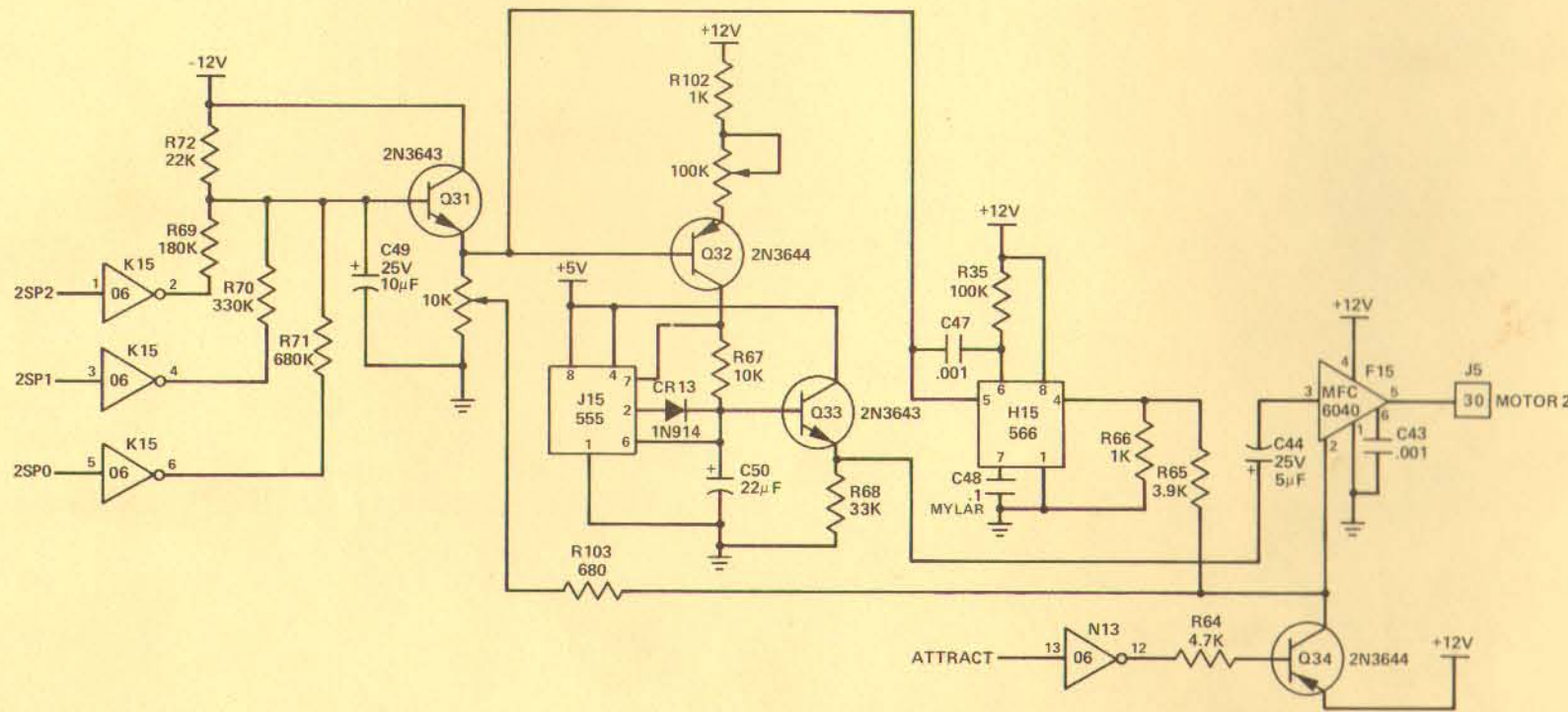

FIGURE 56
MOTOR 2 SOUND SCHEMATIC

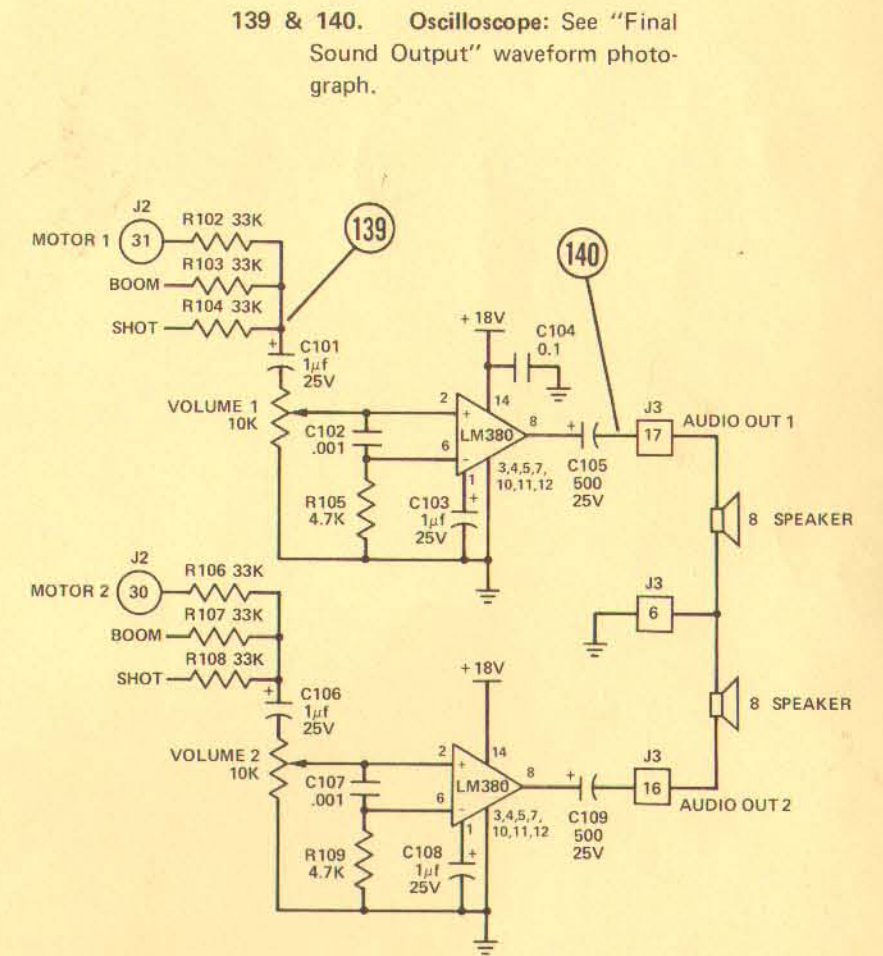

FIGURE 57
AUDIO AMPLIFIER SCHEMATIC

139 & 140. Oscilloscope: See "Final Sound Output" waveform photograph.